

Stellaris[®] LM3S9U96 RevA1 Errata

This document contains known errata at the time of publication for the Stellaris LM3S9U96 microcontroller. The table below summarizes the errata and lists the affected revisions. See the data sheet for more details.

See also the ARM[®] Cortex[™]-M3 errata, ARM publication number PR326-PRDC-009450 v2.0.

Table 1. Revision History

Date	Revision	Description
October 2013	2.3	<ul style="list-style-type: none"> ■ Added issue "Chip select operation is not correct when using dual chip selects in Host Bus Continuous Read mode" on page 16. ■ Added issue "Flash memory may be corrupted if programmed at system clock speeds above 50 MHz" on page 24. ■ Added issue "iRDY timing in General-Purpose mode is not as specified in the data sheet" on page 28. ■ Added issue "Simultaneous sampling on both ADC modules yields incorrect samples" on page 37. ■ Added issue "Phase offset does not delay as expected if sample sequencers are not triggered at the same time" on page 37.
October 2012	2.2	<ul style="list-style-type: none"> ■ Clarified issue "Debug interface is reset by any type of reset" on page 7. ■ Added issue "JTAG state machine may advance after certain resets" on page 10. ■ Added issue "Non-word-aligned write to SRAM can cause incorrect value to be loaded" on page 12. ■ Added issue "Internal reset supervisors may not prevent incorrect device operation during power transitions" on page 13. ■ Added issue "Watchdog clear mechanism described in the data sheet does not work for the Watchdog Timer 1 module" on page 33. ■ Added issue "Watchdog Timer 1 module asserts reset signal even if not programmed to reset" on page 33. ■ Added issue "WDTLOAD yields an incorrect value when read back" on page 34. ■ Added issue "Digital comparator in last step of sequence does not trigger or interrupt" on page 35. ■ Added issue "Digital comparator interrupts do not trigger or interrupt as expected" on page 36. ■ Added issue "Missing trigger or interrupt when multiple sequences configured for processor trigger and different trigger" on page 36. ■ Added issue "ADC sample sequencers priorities are different than expected" on page 36. ■ Added issue "When UART LIN or SIR mode is enabled, μDMA burst transfer does not occur" on page 39. ■ Added issue "UART transfers fail at certain system clock frequency and baud rate combinations" on page 39. ■ Added issue "Freescale SPI Mode at low SSIClk frequencies can yield data corruption" on page 40. ■ Added issue "First two ADC samples from the internal temperature sensor must be ignored" on page 46.

Date	Revision	Description
June 2012	2.1	<ul style="list-style-type: none"> ■ Clarified how to read the date code on Stellaris devices. ■ Clarified wording of issue "USB0DM may be driven after reset" on page 45.
March 2011	2.0	<ul style="list-style-type: none"> ■ Removed issue "The Reset Cause register always reports POR regardless of reset type" as it does not affect this device. ■ Added issue "The ROM_FlashProgram() function may not correctly program the Flash memory above 50 MHz" on page 18. ■ Added issue "In Host-Bus 16 mode, only one byte select is asserted if only 8 bits are read" on page 26. ■ Added issue "When non-blocking reads are pending, EPI accesses can cause the NBRFIFO counter to be incorrectly decremented" on page 26. ■ Added issue "In General-Purpose mode, the framing signal is output regardless of the state of the FRMPIN bit" on page 27. ■ Added issue "In General-Purpose mode, the maximum time to wait for the iRDY signal is derived from the system clock, not the EPI clock" on page 28. ■ Added issue "USB0DM may be driven after reset" on page 45.
September 2011	1.9	<ul style="list-style-type: none"> ■ Started tracking revision history. ■ Added issue "Boundary scan is not functional" on page 5. ■ Added issue "The Reset Cause register always reports POR regardless of reset type". ■ Added issue "The ROM_FlashProgram() function may not correctly program the Flash memory above 50 MHz" on page 18. ■ Added issue "At EPI clock speeds over 15 MHz, SDRAM initialization delay is not long enough" on page 26. ■ Added issue "LIN mode Sync Break does not have the correct length" on page 38.

Table 2. List of Errata

Erratum Number	Erratum Title	Module Affected	Revision(s) Affected
1.1	Boundary scan is not functional	JTAG	A1, A2
2.1	The PIOSC cannot be calibrated by the user	System Control	A1, A2
2.2	Brown-out interrupt is never triggered	System Control	A1
2.3	Debug interface is reset by any type of reset	System Control	A1, A2
2.4	JTAG state machine may advance after certain resets	System Control	A1, A2
2.5	Non-word-aligned write to SRAM can cause incorrect value to be loaded	System Control	A1, A2
2.6	Internal reset supervisors may not prevent incorrect device operation during power transitions	System Control	A1, A2
2.7	Chip select operation is not correct when using dual chip selects in Host Bus Continuous Read mode	System Control	A1, A2
3.1	Some ROM functions are incorrect	ROM	A1

Erratum Number	Erratum Title	Module Affected	Revision(s) Affected
3.2	The ROM_FlashProgram() function may not correctly program the Flash memory above 50 MHz	ROM	A1, A2
4.1	Deep-Sleep mode must not be used	Flash Memory	A1, A2
4.2	Mass erase must not be used if Flash protection bits are used	Flash Memory	A1, A2
4.3	Page erase or program must not be performed on a protected Flash page	Flash Memory	A1, A2
4.4	The BOOTCFG register cannot be reliably written until after a special mass erase	Flash Memory	A1
4.5	Flash corruption or device failure may occur at power on	Flash Memory	A1
4.6	Flash memory endurance cycle specification is 100 cycles	Flash Memory	A1, A2
4.7	Flash memory may be corrupted if programmed at system clock speeds above 50 MHz	Flash Memory	A1, A2
5.1	The μ DMA controller fails to generate capture mode DMA requests from Timer A in the Timer modules	μ DMA	A1, A2
5.2	The μ DMA does not generate a completion interrupt when transferring to and from GPTM 2A and 2B	μ DMA	A1, A2
6.1	PB1 has permanent internal pull-up resistance	GPIO	A1, A2
7.1	At EPI clock speeds over 15 MHz, SDRAM initialization delay is not long enough	EPI	A1, A2
7.2	In Host-Bus 16 mode, only one byte select is asserted if only 8 bits are read	EPI	A1, A2
7.3	When non-blocking reads are pending, EPI accesses can cause the NBRFIFO counter to be incorrectly decremented	EPI	A1, A2
7.4	In General-Purpose mode, the framing signal is output regardless of the state of the FRMPIN bit	EPI	A1, A2
7.5	In General-Purpose mode, the read and write strobes are output regardless of the state of the RW bit	EPI	A1, A2
7.6	In General-Purpose mode, the maximum time to wait for the iRDY signal is derived from the system clock, not the EPI clock	EPI	A1, A2
7.7	iRDY timing in General-Purpose mode is not as specified in the data sheet	EPI	A1, A2
8.1	The General-Purpose Timer match register does not function correctly in 32-bit mode	General-Purpose Timers	A1, A2
8.2	A spurious DMA request is generated when the timer rolls over in Input-Edge Time mode	General-Purpose Timers	A1, A2
8.3	A spurious DMA request is generated when the timer rolls over the 16-bit boundary	General-Purpose Timers	A1, A2
8.4	The value of the prescaler register is not readable in Edge-Count mode	General-Purpose Timers	A1, A2
8.5	ADC trigger and Wait-on-Trigger may assert when the timer is disabled	General-Purpose Timers	A1, A2

Erratum Number	Erratum Title	Module Affected	Revision(s) Affected
8.6	Wait-on-Trigger does not assert unless the TnOTE bit is set	General-Purpose Timers	A1, A2
8.7	Do not enable match and timeout interrupts in 16-bit PWM mode	General-Purpose Timers	A1, A2
8.8	Do not use μ DMA with 16-bit PWM mode	General-Purpose Timers	A1, A2
8.9	Writing the GPTMTnV register does not change the timer value when counting up	General-Purpose Timers	A1, A2
8.10	The prescaler does not work correctly when counting up in periodic or one-shot mode	General-Purpose Timers	A1, A2
8.11	Snapshot must be enabled in both Timer A and B when in 32-bit snapshot mode	General-Purpose Timers	A1, A2
9.1	Watchdog clear mechanism described in the data sheet does not work for the Watchdog Timer 1 module	Watchdog Timers	A1, A2
9.2	Watchdog Timer 1 module asserts reset signal even if not programmed to reset	Watchdog Timers	A1, A2
9.3	WDTLOAD yields an incorrect value when read back	Watchdog Timers	A1, A2
10.1	The encoding of the VREF field in the ADCCTL register is incorrect	ADC	A1, A2
10.2	ADC errors exceed specifications	ADC	A1
10.3	Retriggering a sample sequencer before it has completed the current sequence results in continuous sampling	ADC	A1, A2
10.4	Digital comparator in last step of sequence does not trigger or interrupt	ADC	A1, A2
10.5	Digital comparator interrupts do not trigger or interrupt as expected	ADC	A1, A2
10.6	Missing trigger or interrupt when multiple sequences configured for processor trigger and different trigger	ADC	A1, A2
10.7	ADC sample sequencers priorities are different than expected	ADC	A1, A2
10.8	Simultaneous sampling on both ADC modules yields incorrect samples	ADC	A1, A2
10.9	Phase offset does not delay as expected if sample sequencers are not triggered at the same time	ADC	A1, A2
11.1	The RTRIS bit in the UARTRIS register is only set when the interrupt is enabled	UART	A1, A2
11.2	LIN mode Sync Break does not have the correct length	UART	A1, A2
11.3	When UART LIN or SIR mode is enabled, μ DMA burst transfer does not occur	UART	A1, A2
11.4	UART transfers fail at certain system clock frequency and baud rate combinations	UART	A1, A2
12.1	Freescale SPI Mode at low SSIClk frequencies can yield data corruption	SSI	A1, A2
13.1	Encoding error in the Ethernet MAC LED Encoding (MACLED) register	Ethernet Controller	A1, A2
14.1	USB compliance test issue: USB full-speed, far-end signal compliance tests fail with 5 m cable	USB	A1

Erratum Number	Erratum Title	Module Affected	Revision(s) Affected
14.2	USB compliance test issue: USB embedded host low-speed, far-end signal compliance tests fail	USB	A1
14.3	MCU may fail USB certification if the EPI module is operating	USB	A1, A2
14.4	Special considerations for PB1	USB	A1, A2
14.5	Cannot communicate with a low-speed Device through a hub	USB	A1, A2
14.6	USB0DM may be driven after reset	USB	A1, A2
15.1	PWM fault latch does not operate correctly	PWM	A1, A2
16.1	First two ADC samples from the internal temperature sensor must be ignored	Electrical Characteristics	A1, A2

1 JTAG

1.1 Boundary scan is not functional

Description:

The boundary scan is not functional on this device.

Workaround:

None.

Silicon Revision Affected:

A1, A2

Fixed:

Fixed on devices with date codes of 1A (October, 2011) or later.

Note: To determine the date code of your part, look at the first two characters following the dash on the third line of the part markings (highlighted in red in the following figure). The first number after the dash indicates the last decimal digit of the year. The second character indicates the month. Therefore, the following example shows a date code of 9B which indicates November 2009.



2 System Control

2.1 The PIOSC cannot be calibrated by the user

Description:

The PIOSC is trimmed by the factory, but cannot be user calibrated using the `UPDATE` bit in the **Precision Internal Oscillator Calibration (PIOSCCAL)** register.

Workaround:

None.

Silicon Revision Affected:

A1, A2

Fixed:

Fixed on devices with date codes of 17 (July, 2011) or later.

Note: To determine the date code of your part, look at the first two characters following the dash on the third line of the part markings (highlighted in red in the following figure). The first number after the dash indicates the last decimal digit of the year. The second character indicates the month. Therefore, the following example shows a date code of 9B which indicates November 2009.

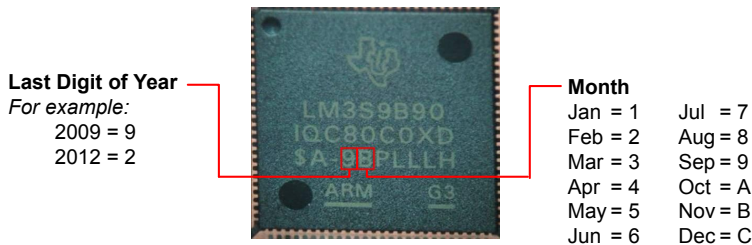

2.2 Brown-out interrupt is never triggered

Description:

The brown out circuitry always resets the microcontroller when V_{DD} drops to the brown-out threshold voltage (V_{BTH}), regardless of the state of the `BORIOR` bit in the **PBORCTL** register.

Workaround:

None.

Silicon Revision Affected:

A1

Fixed:

Fixed on devices with date codes of 17 (July, 2011) or later.

Note: To determine the date code of your part, look at the first two characters following the dash on the third line of the part markings (highlighted in red in the following figure). The first number after the dash indicates the last decimal digit of the year. The second character

indicates the month. Therefore, the following example shows a date code of 9B which indicates November 2009.



2.3 Debug interface is reset by any type of reset

Description:

The Serial Wire JTAG Debug Port (SWJ-DP) is reset by any reset condition. Therefore, any access to a debugger is lost, including breakpoints, watchpoints, vector catch, and trace. These reset types include:

- Watchdog reset
- Brown-out reset
- Software reset
- Reset pin assertion
- Main oscillator fail

Normal operation of the device is not affected by the reset of the SWJ-DP, however, users should bear this functionality in mind during development and debugging of applications. If a debugger does a `SYSRESREQ`, or if the debugger is being used in a session and a system reset occurs due to one of the reset sources above, then the debugger loses its state, including breakpoints, watchpoints, vector catch, and trace. Most debuggers attempt a recovery, usually after reporting the error to the user. If the debugger is able to recover control, the state of the application at that time reflects that the code has been running from reset and has not stopped on any breakpoints. If the application has breakpoint instructions physically in the code, such as for system calls that run through the debugger, then the code will have entered the fault handlers.

Workaround:

Because some ARM debuggers expect to maintain connectivity when a system reset is requested, the `SYSRESREQ` bit in the **Application Interrupt and Reset Control (APINT)** register should not be used when using these debuggers; instead the `VECTRESET` bit, which only resets the core, should be used so that debug connectivity is uninterrupted. `VECTRESET` does not reset on-chip peripherals, which must be reset with specific reset operations.

When debugging code that requires a software reset, the `SYSRESREQ` software reset mechanism in the NVIC (which is used by the Stellaris Peripheral Driver Library `SysCtlReset()` and `ROM_SysCtlReset()` APIs) should not be used; instead, use the sequence of register writes with a `VECTRESET` in the NVIC as shown in the code below.

In addition, the ROM is mapped into address 0x0 during reset. The ROM code determines if boot loading is needed, and if not, transfers control to the normal application in Flash memory. As a result, the ROM is visible to the debugger on the reset entry. Debugging can be affected during Flash memory verification because the debugger compares the expected image with the ROM

contents and not the Flash memory as intended. The disassembly shown to the user is also affected. To avoid these issues, debuggers must switch off the ROM mapping. However, if the debugger in use does not switch off the ROM, the user can either step through the first assembly instructions until the ROM gets remapped or write a 1 to the BA bit in the **ROM Control (ROMCTL)** register at location 0x400F.E0F0 using the debugger GUI, debugger command line, or debugger startup script.

Use of any reset source listed above other than software reset causes the debugger to lose connectivity.

A consequence to using VECTRESET and a debugger simultaneously, as described in the workaround, is that the USB may fail to enumerate when using a debugger. When debugging a board with USB and a crystal with a frequency greater than 8 MHz, the debugger writes the **RCC** register with the XTAL value for 8 MHz. As a result, the USB PLL cannot lock onto the required frequency and requires a hard reset.

When debugging with USB and a crystal greater than 8 MHz, always disable the USB PLL before writing the **RCC** XTAL value to ensure that the USB PLL starts up correctly.

```
//
// Disable processor interrupts.
//
IntMasterDisable();

//
// Disable the PLL and the system clock divider (this is a NOP if they are
// already disabled).
//
HWREG(SYSCTL_RCC) = ((HWREG(SYSCTL_RCC) & ~(SYSCTL_RCC_USESYSDIV)) |
                    SYSCTL_RCC_BYPASS);
HWREG(SYSCTL_RCC2) |= SYSCTL_RCC2_BYPASS2;

//
// Now, write RCC and RCC2 to their reset values.
//
HWREG(SYSCTL_RCC) = 0x078e3ad0 | (HWREG(SYSCTL_RCC) & SYSCTL_RCC_MOSCDIS);
HWREG(SYSCTL_RCC2) = 0x07806810;
HWREG(SYSCTL_RCC) = 0x078e3ad1;

//
// Reset the deep sleep clock configuration register.
//
HWREG(SYSCTL_DSLPCLKCFG) = 0x07800000;

//
// Reset the clock gating registers.
//
HWREG(SYSCTL_RCGC0) = 0x00000040;
HWREG(SYSCTL_RCGC1) = 0;
HWREG(SYSCTL_RCGC2) = 0;
HWREG(SYSCTL_SCGC0) = 0x00000040;
HWREG(SYSCTL_SCGC1) = 0;
HWREG(SYSCTL_SCGC2) = 0;
HWREG(SYSCTL_DCGC0) = 0x00000040;
HWREG(SYSCTL_DCGC1) = 0;
HWREG(SYSCTL_DCGC2) = 0;
```



```
//
// Reset the remaining SysCtl registers.
//
HWREG(SYSCTL_PBORCTL) = 0;
HWREG(SYSCTL_IMC) = 0;
HWREG(SYSCTL_GPIOHCTL) = 0;
HWREG(SYSCTL_MOSCCTL) = 0;
HWREG(SYSCTL_PIOCCAL) = 0;
HWREG(SYSCTL_I2SMCLKCFG) = 0;

//
// Reset the peripherals.
//
HWREG(SYSCTL_SRCR0) = 0xffffffff;
HWREG(SYSCTL_SRCR1) = 0xffffffff;
HWREG(SYSCTL_SRCR2) = 0xffffffff;
HWREG(SYSCTL_SRCR0) = 0;
HWREG(SYSCTL_SRCR1) = 0;
HWREG(SYSCTL_SRCR2) = 0;

//
// Clear any pending SysCtl interrupts.
//
HWREG(SYSCTL_MISC) = 0xffffffff;

//
// Wait for any pending flash operations to complete.
//
while((HWREG(FLASH_FMC) & 0xffff) != 0)
{
}
while((HWREG(FLASH_FMC2) & 0xffff) != 0)
{
}

//
// Reset the flash controller registers.
//
HWREG(FLASH_FMA) = 0;
HWREG(FLASH_FCIM) = 0;
HWREG(FLASH_FCMISC) = 0xffffffff;
HWREG(FLASH_FWBVAL) = 0;

//
// Issue the core reset.
//
HWREG(NVIC_APINT) = NVIC_APINT_VECTKEY | NVIC_APINT_VECT_RESET;
```

Silicon Revision Affected:

A1, A2

Fixed:

Not yet fixed.

2.4 JTAG state machine may advance after certain resets

Description:

Due to an issue with the reset logic, the JTAG state machine may advance to a random state if one of the following resets occurs:

- Hardware Reset via the \overline{RST} pin
- Brown-Out Reset
- Software System Request Reset (using SYSRESREQ)
- Watchdog Reset
- MOSC Failure Reset

On most devices, these state transitions do not cause any noticeable problems. Some devices, however, eventually execute random JTAG instructions after multiple resets of the type listed above. Since some JTAG instructions can interfere with device operation, steps must be taken to avoid this behavior in a production environment.

In a development environment where a JTAG debugger is being used, this issue is likely to go unnoticed. Many JTAG debuggers pull TCK Low after establishing a connection with the device, which prevents the random state transitions from happening. Also, many JTAG debuggers reset the microcontroller using VECTRESET instead of SYSRESREQ, which also avoids the problem.

Workaround:

There are two workarounds, each with trade-offs:

- Connect TCK to GND through a 10-K resistor in the final board design. This avoids the problem completely but it causes the chip to draw a small amount of additional current, since the default pin configuration of TCK includes a weak internal pull-up resistor.
- Implement a software routine to explicitly reset the JTAG state machine after every system reset. This works for most cases, but it does not protect the ROM boot loader from erroneous JTAG instruction execution.

```
void
ResetJTAGState(void)
{
    volatile unsigned char ucToggleCount, ucDelayCount;

    //
    // Enable GPIO port C
    //
    HWREG(SYSCTL_RCGC2) = SYSCTL_RCGC2_GPIOC;

    //
    // Dummy read to make sure GPIO port C has time to enable before we
    // proceed.
    //
    ucToggleCount = HWREG(SYSCTL_RCGC2);

    //
    // Unlock the GPIOs on port C
```

```

//
HWREG(GPIO_PORTC_BASE + GPIO_O_LOCK) = GPIO_LOCK_KEY_DD;
HWREG(GPIO_PORTC_BASE + GPIO_O_CR) = 0x01;

//
// "Toggle" TCK at least 5 times while TMS remains high. We're relying on a
// digitally disabled pin to feed a "zero" into the JTAG module, and we're
// also relying on an external pull-up to feed us our "one". To be extra
// conservative, let's try 10 toggles.
//
for(ucToggleCount = 0; ucToggleCount < 10; ucToggleCount++)
{
    //
    // Turn off the digital enable for PC0
    //
    HWREG(GPIO_PORTC_BASE + GPIO_O_DEN) &= ~(0x01);

    //
    // Delay a little to make sure the signal propagates through the JTAG
    // state machine (make sure these delays do not get optimized out by
    // the compiler).
    //
    for(ucDelayCount=0; ucDelayCount<100; ucDelayCount++)
    {
    }

    //
    // Turn on the digital enable for PC0
    //
    HWREG(GPIO_PORTC_BASE + GPIO_O_DEN) |= 0x01;

    //
    // Delay a little
    //
    for(ucDelayCount=0; ucDelayCount<100; ucDelayCount++)
    {
    }
}
}

```

Silicon Revision Affected:

A1, A2

Fixed:

Not yet fixed.

2.5 Non-word-aligned write to SRAM can cause incorrect value to be loaded

Description:

If a word-aligned value is loaded from an SRAM location into a core register, then altered by storing a byte or halfword at an unaligned offset, the altered word-aligned value is not correctly indicated when loaded into a core register. The loaded value from the SRAM location into a core register reflects the original value, not the modified value.

The following assembly sequence causes the altered value loaded into a core register to not load the correct value, even though the correct value is visible in the SRAM memory location.

```
//  
// Load a word-aligned value from an SRAM location into a  
// core register (such as R0)  
//  
LDR      R0, [SP, #+0];  
  
//  
// Store byte or halfword from the core register to  
// the SRAM location at a non-word-aligned offset  
//  
STRB     R0, [SP, #+1];  
        OR  
STRB     R0, [SP, #+2];  
        OR  
STRB     R0, [SP, #+3];  
        OR  
STRH     R0, [SP, #+1];  
  
//  
// Load the same word-aligned value of the same SRAM location  
// into a core register (such as R0)  
//  
LDR      R0, [SP, #+0];
```

This assembly sequence causes erroneous values only if these three instructions are executed in this order. However, the three instructions do not have to be consecutive, which means that other instructions can be placed in between the first and the second instructions, or the second and the third instructions, and the false value still occurs. Other instructions include, but are not limited to, branches in Flash, accesses to non-SRAM locations such as peripherals, and writes to other SRAM locations.

Pointers, structures, and unions are common C code methods that can be found in user code that may generate this assembly sequence and, therefore, result in incorrect values for variables. If using interrupts, it is possible to continue the assembly sequence in the interrupt handler, which could also return incorrect data.

For more information about this erratum as well as C code examples that may generate this assembly sequence, refer to the document, *Non-Word-Aligned Write to SRAM Additional Information* (SPMA047).

Workaround:

The type of compiler and optimization settings used in your application affects whether the problematic assembly code is generated from your user code. Each compiler behaves a little differently with respect to this erratum. The behavior for each compiler is not guaranteed due to the large number of compiler and tool version combinations.

At the assembly level, loading a volatile 32-bit-aligned word value from a different address in SRAM after storing and before loading in the assembly instruction sequence yields a correct value. A dummy SRAM load of a volatile 32-bit-aligned word from a different SRAM memory location should be inserted after the second assembly instruction (storing a byte or halfword from the core register to the desired SRAM location at a non-word-aligned offset) and before the third assembly instruction (loading the same word-aligned value of the desired SRAM location into a core register). This also means that a dummy SRAM load of a volatile 32-bit-aligned word from a different SRAM memory location should also be placed at the beginning of any interrupt routine, in case the third assembly instruction is executed before leaving the handler.

For more information about this erratum as well as C code examples that may generate this assembly sequence, refer to the document, *Non-Word-Aligned Write to SRAM Additional Information* (SPMA047).

Silicon Revision Affected:

A1, A2

Fixed:

Not yet fixed.

2.6 Internal reset supervisors may not prevent incorrect device operation during power transitions

Description:

This microcontroller incorporates internal Power-On Reset (POR) and Brown-Out Reset (BOR) supervisors to ensure that code only executes when power to the device is within specification. However, gaps in the voltage and timing thresholds of the internal supervisors result in a risk of incorrect operation during VDD power transitions.

Unexpected operation may occur that can include brief execution of random sections of user code including ROM functions and random instructions, as well as incorrect power-up initialization. The uncontrolled brief execution of random instructions may result in the undesired erasing or writing of non-volatile memories and GPIO state changes. There is also the possibility that the device may be left in a state where it does not operate correctly until a clean power cycle has been completed.

The Power-On Reset gap occurs because the supervisor can release internal state machine operation as soon as 6.0 ms after the VDD supply reaches 1.9 V. If VDD is still below the minimum operating voltage of 3.0 V after 6.0 ms, the power-up state machine may not function correctly, resulting in the effects described above. The $\overline{\text{RST}}$ pin of the device has no effect on the initialization state machine, therefore, a complete power-cycle is required to restore the initialization state machine.

The Brown-Out Reset threshold (V_{BTH}) gap occurs because the brown-out supervisor has a threshold as low as 2.85 V, which is less than the minimum operating voltage on VDD, and also because it can take several microseconds to respond. BOR gaps can be encountered after power up, during steady state operation power-on, if the VDD rail has glitches, and also during power-down.

Workaround:

After initial power-up, any processor operation with VDD below 3.0 V may result in unexpected code execution resulting in the effects described above. The processor must be halted or the $\overline{\text{RST}}$ signal must be driven Low prior to VDD dropping below 3.0 V and stay in that state until VDD is above 3.0 V.

If VDD falls below 2.1 V, it must continue to fall until it reaches 1.5 V. VDD must stay below 1.5 V for at least 36 μs to ensure that a POR is triggered correctly. Additionally, the VDD power-up time between 1.9 V and 3.0 V must be at most 6.0 ms. If VDD falls below 3.0 V but stays above 2.1 V, it is not necessary for the voltage to continue falling below 2.1 V. VDD can come back up to 3.0 V without any additional timing requirements.

The system designer must ensure they meet the requirements listed below for power-up, steady state, and power-down:

1. The VDD power-up, steady state, and power-down waveform meets the timing requirements shown in Figure 1 on page 15.
2. The power-up transition of VDD between 1.9 V and 3.0 V must not have any points where it decreases in voltage (must be monotonic).
3. The power-down transition of VDD between 3.0 V and 1.5 V must not have any points where it increases in voltage (must be monotonic).
4. Once steady-state operation between 3.0 V and 3.6 V is achieved, $\overline{\text{RST}}$ must go Low or the CPU execution must be halted prior to VDD falling below 3.0 V.
5. The **Brown-Out Reset Control (PBORCTL)** register must be set so that a brown-out event causes a reset.

Depending on the system environment requirement, items 3, 4, and 5 in the above list may be met by using a voltage supervisor, such as the TLV803M, to monitor a higher voltage rail from which the VDD supply is regulated. Figure 2 on page 15 shows this implementation with a voltage supervisor monitoring the 5-V rail and a voltage trip point of 4.38 V. A voltage supervisor with a lower voltage trip point can be used to monitor the VDD (3.3-V) rail, however this supervisor must assert reset before VDD reaches 3.0 V. Regardless of the implemented voltage supervisor circuit, the system designer must ensure that there is enough time to assert $\overline{\text{RST}}$ Low prior to VDD falling below 3.0 V. Figure 3 on page 16 shows the resulting waveform of the circuit shown in Figure 2 on page 15.

Figure 1. VDD Waveform Signature Limits

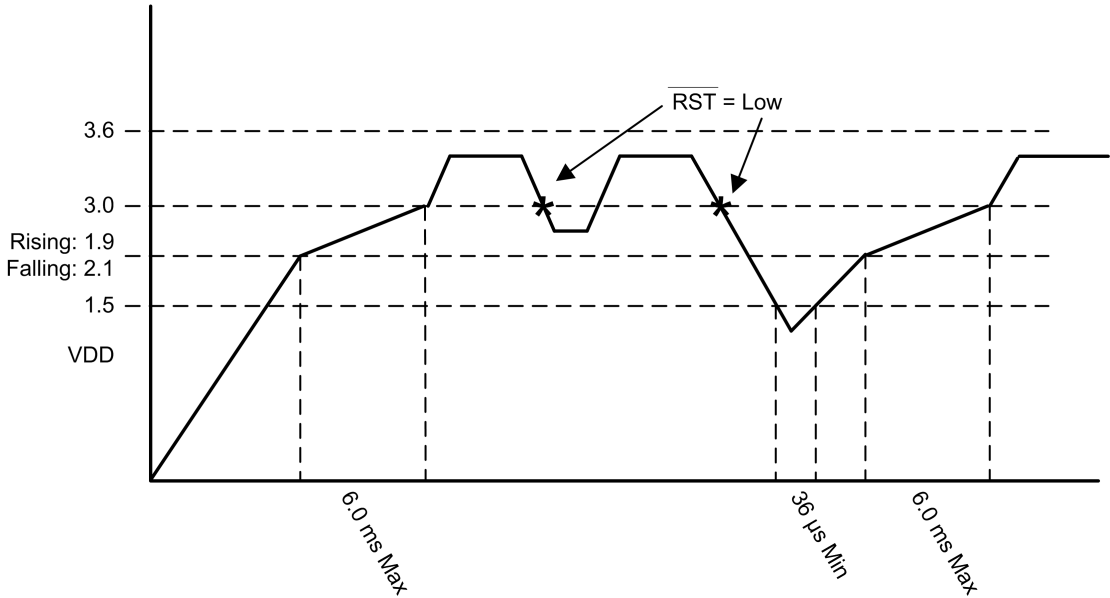

Figure 2. Using a Voltage Supervisor to Monitor the Voltage Rail

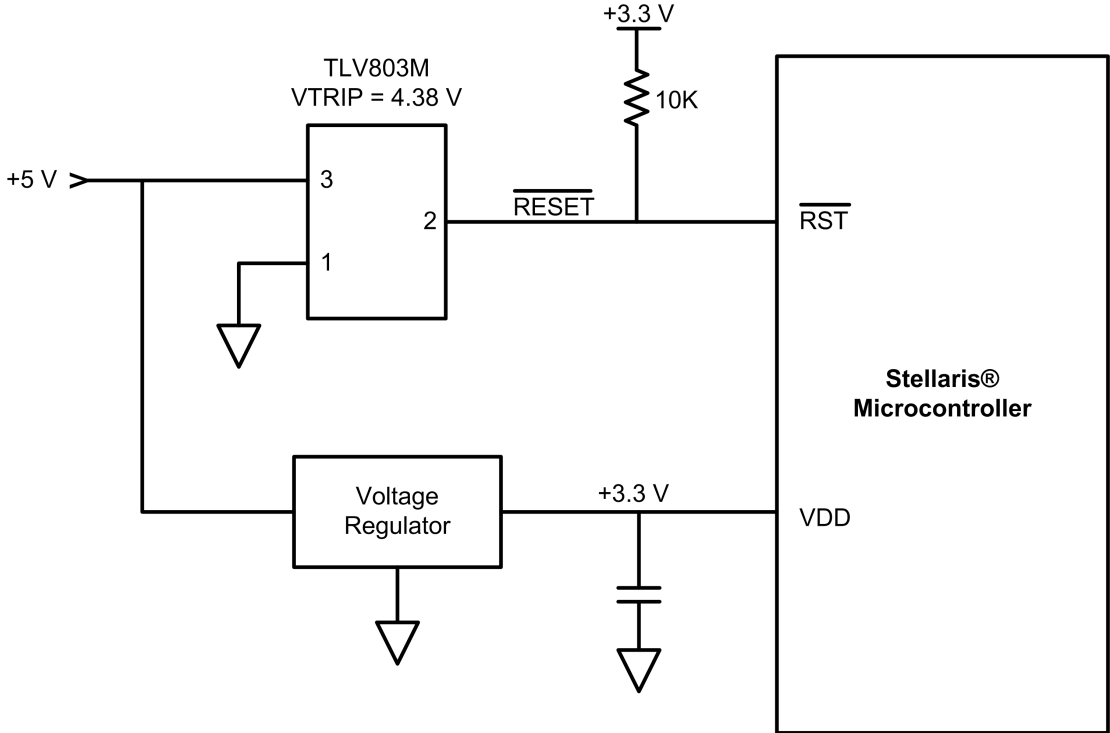
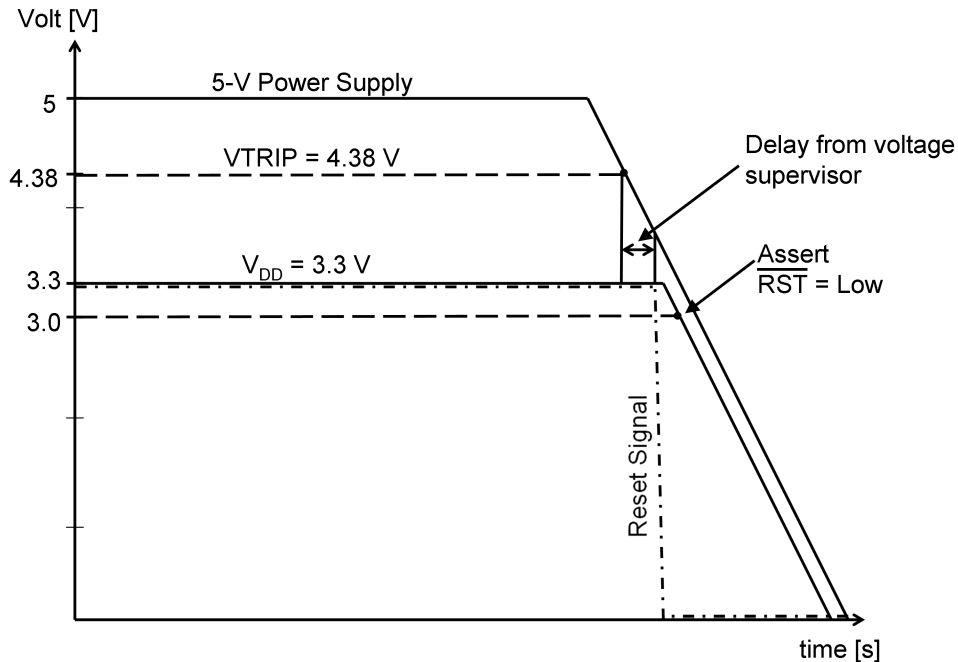

Figure 3. Resulting Waveform Using the Voltage Supervisor Circuit

**Silicon Revision Affected:**

A1, A2

Fixed:

Not yet fixed.

2.7 Chip select operation is not correct when using dual chip selects in Host Bus Continuous Read mode

Description:

Chip select operation for the first read is not correct when the EPI module is in Host Bus mode and is configured to use dual chip selects (the `CSCFG` field in the `EPIHBnCFG2` register is `0x2`) and Continuous Read mode (the `MODE` field in the `EPIHBnCFG` register is `0x2`). When accessing a memory region assigned to one chip select, the other chip select is asserted first along with the RD strobe. This incorrect chip select is de-asserted before the next EPI clock edge and the correct chip select is asserted on that EPI clock edge. The RD strobe remains asserted, but the number of cycles that it is asserted includes the time that it is asserted with the incorrect chip select.

For example, if the RD strobe is programmed to be asserted for two clocks (the `RDWS` field in the `EPIHBnCFG` register is `0x0`), the signal is asserted for one clock cycle with the incorrect chip select and one clock cycle with the correct chip select. As long as the width of the RD strobe is adjusted for this one clock difference, data is read correctly in this mode. Figure 4 on page 17 shows the read and chip select timing of this example when accessing a memory region assigned to CS0n.

Subsequent reads while the OE signal is asserted operate as expected.

Workaround:

Use a value in the `RDWS` field in the `EPIHBnCFG` register that is 1 more than required for the peripheral in the system.

For example, if the peripheral requires a read strobe that is 4 EPI clocks wide, set the `MODE` field to be 0x2 (6 clocks) to account for the 1 clock difference in the strobe width.

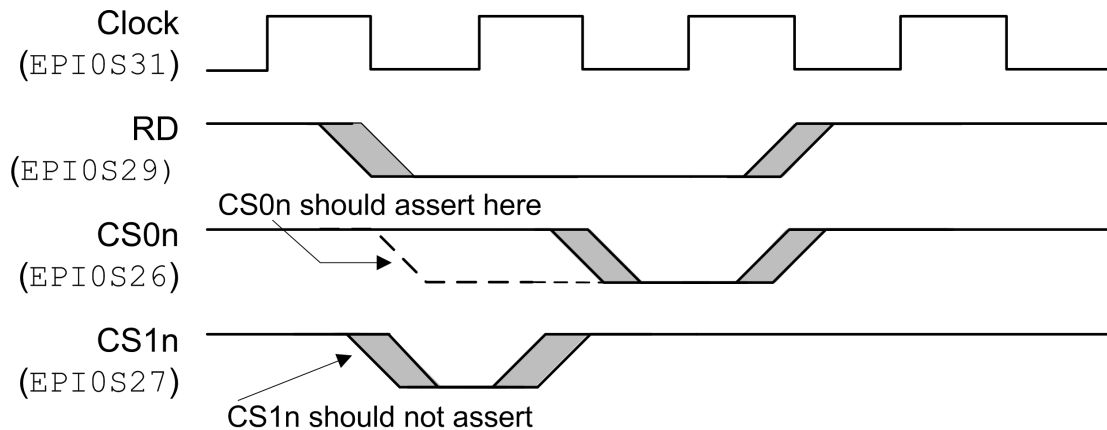
Figure 4. Chip Selects**Silicon Revision Affected:**

A1, A2

Fixed:

Not yet fixed.

3 ROM

3.1 Some ROM functions are incorrect

Description:

The following ROM functions do not work and should not be used.

- ROM_USBHostMode
- ROM_CANBitRateSet
- ROM_uDMAChannelTransferSet

Workaround:

Use the StellarisWare functions in Flash memory.

Silicon Revision Affected:

A1

Fixed:

Fixed in Rev A2.

3.2 The ROM_FlashProgram() function may not correctly program the Flash memory above 50 MHz

Description:

The ROM_FlashProgram() function may not correctly program the Flash memory when the system clock is above 50 MHz. As a result, the ROM boot loader may not function at system clock speeds above 50 MHz.

Workaround:

When using the ROM_FlashProgram() function, ensure that the system clock frequency is no higher than 50 MHz or load the StellarisWare version of FlashProgram() into Flash memory and use that version of the function. When invoking the ROM boot loader, do not use system clock frequencies above 50 MHz.

Silicon Revision Affected:

A1, A2

Fixed:

Not yet fixed.

4 Flash Memory

4.1 Deep-Sleep mode must not be used

Description:

Deep-sleep mode must not be used.

Due to this erratum, the use of this device in USB bus-powered applications is prohibited because sleep mode current consumption exceeds the USB specification.

Workaround:

Use Sleep or Hibernation mode.

Silicon Revision Affected:

A1, A2

Fixed:

Not yet fixed.

4.2 Mass erase must not be used if Flash protection bits are used

Description:

The mass erase function using the `MERASE` bit in the **Flash Memory Control (FMC)** register must not be used in systems that clear any of the **Flash Memory Protection Program Enable n (FMPPE_n)** bits. For Rev A1 and A2 devices, mass erase can be used as long as none of the **FMPPE_n** bits are cleared.

Workaround:

Erase Flash memory with the page erase function using the `ERASE` bit in the **FMC** register instead of the mass erase function.

Silicon Revision Affected:

A1, A2

Fixed:

Not yet fixed.

4.3 Page erase or program must not be performed on a protected Flash page

Description:

The erase function using the `ERASE` bit in the **Flash Memory Control (FMC)** register and the program function using the `WRITE` bit in the **FMC** register or the `WRBUF` bit in the **FMC2** register must not be used in systems that clear the bit in **FMPPE_n** that corresponds to that page of Flash. For Rev A1 and A2 devices, erase and program can be used as long as neither of the corresponding **FMPPE_n** bits are cleared.

Workaround:

Only erase and program memory that is not protected by the corresponding **FMPPE_n** bits.

Silicon Revision Affected:

A1, A2

Fixed:

Not yet fixed.

4.4 The **BOOTCFG** register cannot be reliably written until after a special mass erase

Description:

The **Boot Configuration (BOOTCFG)** register cannot be reliably written until a special type of mass erase is executed.

Workaround:

Execute the special mass erase sequence described in “Recovering a 'Locked' Microcontroller” section of the JTAG chapter prior to a write access to the **BOOTCFG** register. The debug port unlock sequence in LMFlash Programmer can be used to perform this special type of mass erase.

Silicon Revision Affected:

A1

Fixed:

Fixed on devices with date codes of 0B (November, 2010) or later.

Note: To determine the date code of your part, look at the first two characters following the dash on the third line of the part markings (highlighted in red in the following figure). The first

number after the dash indicates the last decimal digit of the year. The second character indicates the month. Therefore, the following example shows a date code of 9B which indicates November 2009.

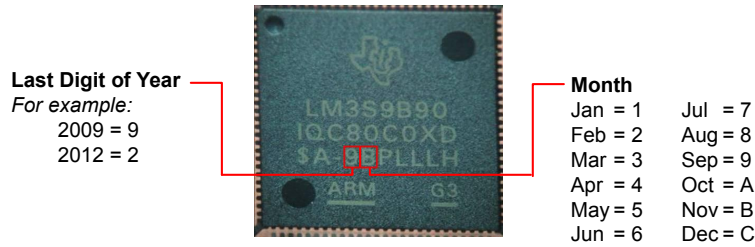

4.5 Flash corruption or device failure may occur at power on

Description:

There is a small risk of flash corruption or device failure on power up. The issue can occur with certain V_{DD} and V_{DDC} power sequences. The failure is not in the flash memory itself but in the control logic to the flash.

Workaround:

To eliminate the risk of flash corruption, two power-on requirements must be met:

- The ramp of both V_{DD} and V_{DDC} must begin below 0.2 V.
- V_{DDC} must reach at least 1.0 V before V_{DD} rises above 1.5 V.

Figure 5 on page 21 details these requirements. Three workaround circuits have been identified that meet these requirements and are described below.

Normally V_{DDC} is supplied by the device's internal voltage regulator from the LDO output pin, however in some circuits the internal regulator may not meet this V_{DDC} timing requirement. A circuit combining an external 1.2 V regulator, a voltage supervisor and a power switch can be used to ensure that this timing requirement are met. The 1.2 V regulator has an integrated Power-OK (POK) circuit that is used to enable V_{DD} when V_{DDC} reaches 1.08 V. During power-down or transient conditions, the POK circuit disables the load switch if V_{DDC} drops below 1.02 V or V_{DD} drops below 1.5 V. The load switch has an internal clamp to accelerate V_{DD} decay.

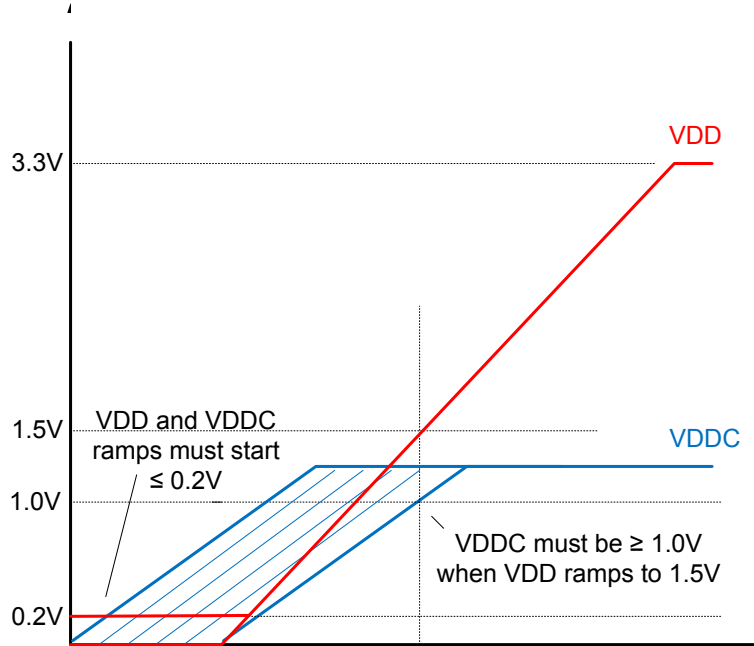
Figure 5. V_{DDC} and V_{DD} Rise Time Relationships

When implementing this workaround, it is important to consider all possible power conditions for the system, including:

- Brown-out (momentary sags in the power source)
- Switch and contact bounce
- Other EMI susceptibility tests
- Various battery and power source disturbances

Three recommended circuits that eliminate the occurrence of this issue are shown below. Although the LDO regulator output is unused in the workaround circuit, a capacitor (1-3 μF) must remain connected for regulator stability. In addition, the LDO pin of the Stellaris device must be disconnected from the external 1.2 V LDO to prevent electronic over stress of the pin. All of these circuits include two jumpers which must be implemented to bypass the workaround circuit for future silicon revisions.

Figure 6 shows a small chip-scale load switch to control V_{DD} . This circuit is suitable for V_{DD} current up to 2 A peak.

Figure 6. Recommended Voltage Supply Circuit 1

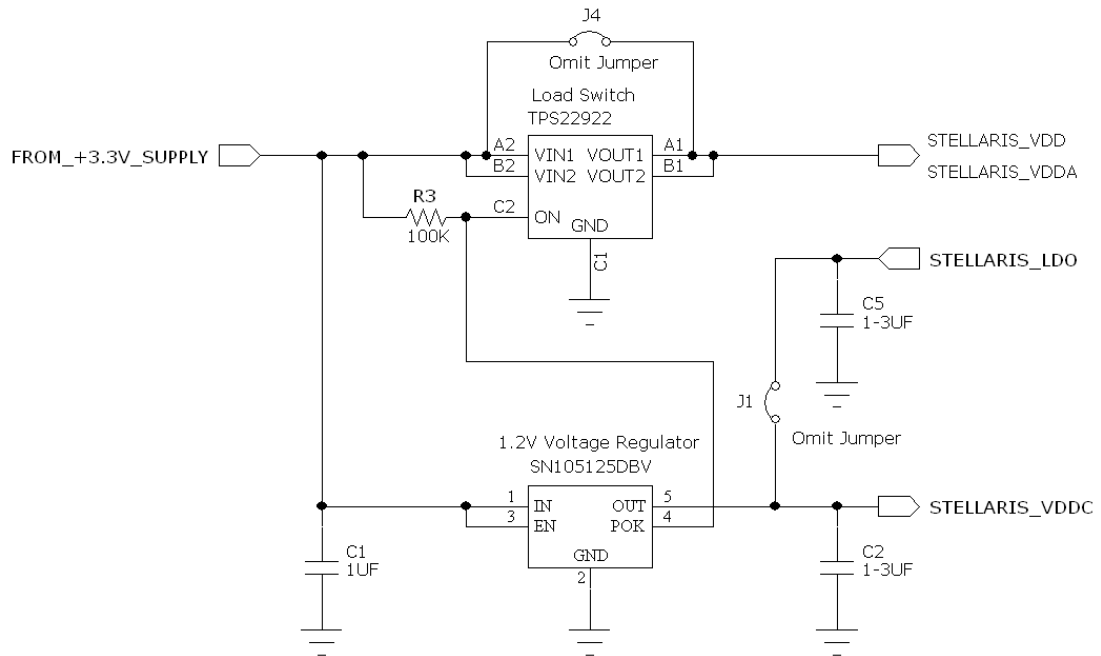

Figure 7 on page 22 shows a larger SOT-packaged load switch with V_{DD} current capabilities up to 400 mA peak (both channels in parallel).

Figure 7. Recommended Voltage Supply Circuit 2

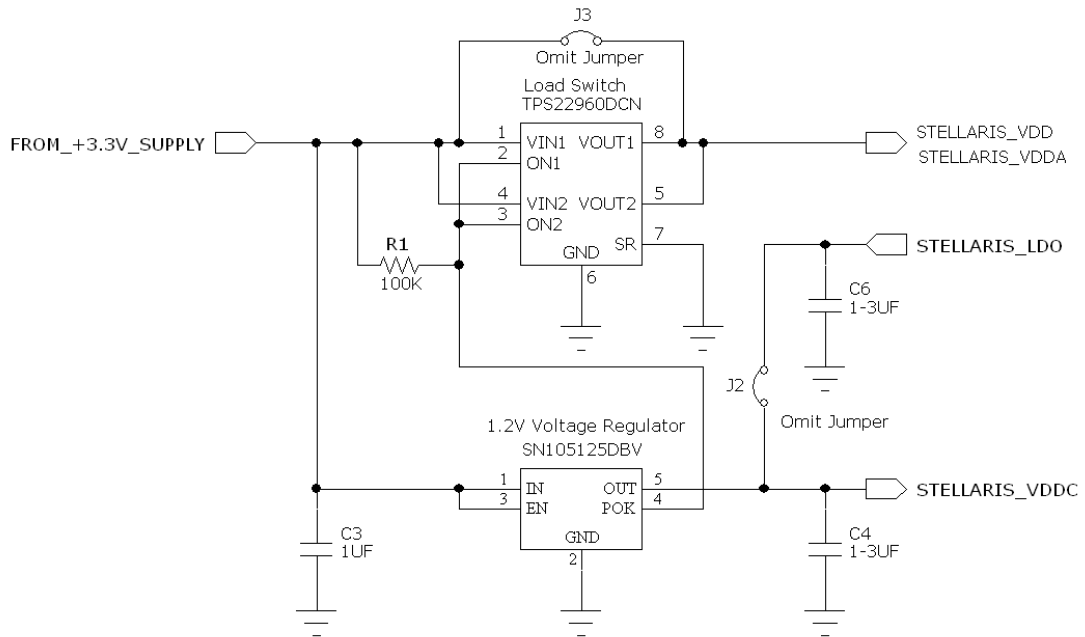
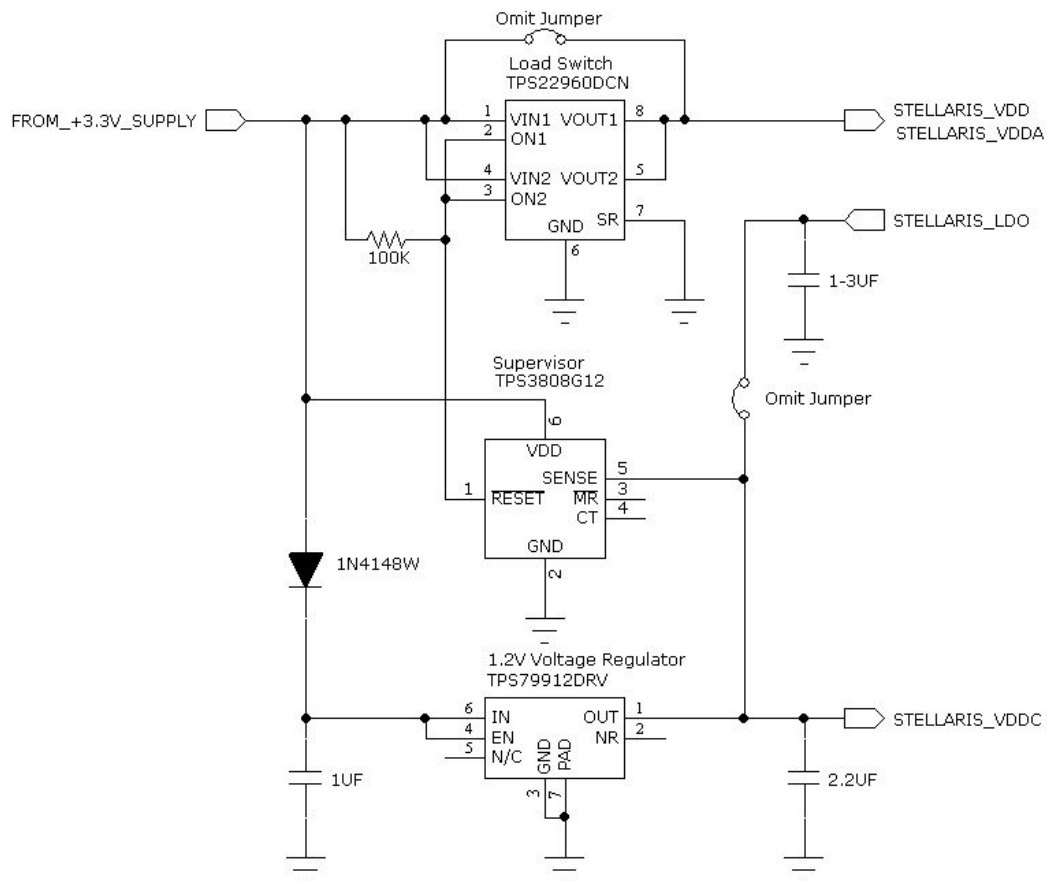

Figure 8 on page 23 is recommended for designs that require an industrial-temperature operating range. The TPS3808G12 is a dedicated 1.2 V voltage supervisor that ensures V_{DD} is only applied once V_{DDC} is valid. An important consideration is the power dissipation in the 1.2 V LDO voltage regulator. The regulator should remain within its thermal limits while accommodating a worst-case V_{DDC} current of 125 mA. The TPS79912DRV regulator has a θ_{ja} of 74.2 °C/W. With a 2.4 V (maximum) voltage drop, the power dissipation is 300 mW. The junction temperature will be approximately 108°C (23°C + 85°C) at 85°C ambient temperature which is well within the rating of the part. For more information about thermal metrics, see the IC Package Thermal Metrics application report, SPRA953.

Figure 8. Recommended Voltage Supply Circuit 3



Silicon Revision Affected:

A1

Fixed:

Fixed on Rev A2.

4.6 Flash memory endurance cycle specification is 100 cycles

Description:

The Flash memory endurance cycle specification (maximum program/erase cycles) is 100 cycles. Failure to adhere to the maximum number of program/erase cycles could result in corruption of the Flash memory contents and/or permanent damage to the device.

Workaround:

None. Because the failure mechanism is a function of the third-party Flash memory technology used in this device, there is no workaround. This third-party Flash memory technology is used only in the affected 130-nm Stellaris products and will not be used in any future devices. All other Stellaris products use Flash memory technology that exceeds industry quality and endurance cycle standards.

Silicon Revision Affected:

A1, A2

Fixed:

Not yet fixed.

4.7 Flash memory may be corrupted if programmed at system clock speeds above 50 MHz

Description:

Flash memory may occasionally be corrupted during programming if the system clock speed is above 50 MHz.

Workaround:

Always program Flash memory with system clock speeds of 50 MHz and below. In addition, it is always a good practice to verify that programming was successful by comparing the Flash memory contents with the expected contents.

Silicon Revision Affected:

A1, A2

Fixed:

Not yet fixed.

5 μ DMA

5.1 The μ DMA controller fails to generate capture mode DMA requests from Timer A in the Timer modules

Description:

The μ DMA controller fails to generate DMA requests from Timer A in the General-Purpose Timer modules when in the Event Count and Event Time modes.

Workaround:

Use Timer B.

Silicon Revision Affected:

A1, A2

Fixed:

Not yet fixed.

5.2 The μ DMA does not generate a completion interrupt when transferring to and from GPTM 2A and 2B

Description:

The μ DMA module does not generate a completion interrupt on the Timer 2 interrupt vector when transferring data to and from Timers 2A and 2B. The μ DMA can successfully transfer data to and from Timers 2A and 2B; however, there is no interrupt to indicate that the transfer is complete.

Workaround:

If a completion interrupt is required, use an alternate GPTM.

Silicon Revision Affected:

A1, A2

Fixed:

Not yet fixed.

6 GPIO

6.1 PB1 has permanent internal pull-up resistance

Description:

Regardless of its configuration (GPIO or alternate digital function), PB1 has a maximum internal pull-up resistance of 800 ohms that turns on when the voltage on the pin is approximately 1.2 V. Due to this internal resistance, up to 3 mA of current may be sourced during the transition from 1.2 V to 3.3 V.

Workaround:

When this pin is configured as an input, the external circuit must drive with an impedance less than or equal to 300 Ω to provide enough drive strength to over-drive the internal pull-up and achieve the necessary V_{IL} voltage level. Ensure that the driver can sink the temporary current. In addition, do not use PB1 in open-drain mode.

if this pin is configured as an output, be aware that if the output was driven high and a non-POR reset occurs, the output may be driven high after reset unless it has a 300- Ω resistor on it. Once the pin is configured as an output, the pin drives the programmed level.

Silicon Revision Affected:

A1, A2

Fixed:

Not yet fixed.

7 EPI

7.1 At EPI clock speeds over 15 MHz, SDRAM initialization delay is not long enough

Description:

After enabling the EPI SDRAM interface via the **EPISDRAMCFG** register, the EPI SDRAM controller should hold off any SDRAM accesses for 100 μ s. When an EPI clock speed greater than 15 MHz is used, it is possible for an access to start before the 100 μ s has elapsed.

Workaround:

After enabling the EPI SDRAM interface in the **EPISDRAMCFG** register, wait 100 μ s before performing any accesses to SDRAM.

Silicon Revision Affected:

A1, A2

Fixed:

Not yet fixed.

7.2 In Host-Bus 16 mode, only one byte select is asserted if only 8 bits are read

Description:

When reading from most 16-bit memories in Host-Bus 16 mode, both byte selects should be asserted for every access, even if only 8 bits are being read. The EPI controller only asserts the byte select for the required 8 bits, violating this specification.

Workaround:

For standard memory configurations, the memory operation proceeds normally. Although this behavior violates the memory specifications, the EPI reads the proper data from memory.

Silicon Revision Affected:

A1, A2

Fixed:

Not yet fixed.

7.3 When non-blocking reads are pending, EPI accesses can cause the NBRFIFO counter to be incorrectly decremented

Description:

When non-blocking reads are pending and the MCU performs a blocking read or a write from any EPI address with bits [11:4] equal to 0x07 or 0x08, the NBRFIFO counter is incorrectly decremented.

Workaround:

When a non-blocking read operation has been initiated, wait for the completion interrupt before performing any additional CPU or μ DMA accesses to or from the EPI registers or the EPI memory space.

Silicon Revision Affected:

A1, A2

Fixed:

Not yet fixed.

7.4 In General-Purpose mode, the framing signal is output regardless of the state of the FRMPIN bit

Description:

In General-Purpose mode, the `FRMPIN` bit in the **EPI General-Purpose Configuration (EPIGPCFG)** register should control whether or not the framing signal, `FRAME`, is output on `EPIS030`. However, the `FRAME` signal is output regardless of the state of the `FRMPIN` bit.

Workaround:

If the `FRMPIN` signal is not required, configure the port pin to an alternate function or a GPIO.

Silicon Revision Affected:

A1, A2

Fixed:

Not yet fixed.

7.5 In General-Purpose mode, the read and write strobes are output regardless of the state of the RW bit

Description:

In General-Purpose mode, the `RW` bit in the **EPI General-Purpose Configuration (EPIGPCFG)** register should control whether or not the read and write strobes, `RD` and `WR`, are output on `EPIS029` and `EPIS028`. However, the `RD` and `WR` signals are output regardless of the state of the `RW` bit.

Workaround:

If the read and write strobes are not required, configure the port pins to an alternate function or GPIOs.

Silicon Revision Affected:

A1, A2

Fixed:

Not yet fixed.

7.6 In General-Purpose mode, the maximum time to wait for the iRDY signal is derived from the system clock, not the EPI clock

Description:

In General-Purpose mode, the `MAXWAIT` field in the **EPI General-Purpose Configuration (EPIGPCFG)** register specifies the number of EPI clocks to wait for the iRDY signal to be deasserted. However, the hardware counts system clocks and not EPI clocks, so the wait may be shorter than expected.

Workaround:

Adjust the `MAXWAIT` configuration to account for the difference in frequency between the system clock and the EPI clock.

Silicon Revision Affected:

A1, A2

Fixed:

Not yet fixed.

7.7 iRDY timing in General-Purpose mode is not as specified in the data sheet

Description:

The data sheet specifies that ready input (iRDY) is sampled on the falling edge of the EPI clock, when it is actually sampled on the rising edge of system clock when configured for General-Purpose mode. The iRDY signal may be seen earlier than expected.

Workaround:

If trying to stall the address phase, this is not an issue. When trying to stall the data phase, you must ensure that iRDY is not deasserted until after the next rising edge of EPICLK. If iRDY misses the set up for the next rising system clock edge, it will be captured on the subsequent rising system clock edge.

For example, if the system clock frequency is configured for 80 MHz (12.5 ns period) and the EPI clock frequency is configured for 40 MHz (25 ns period), there is a 2.5 ns window $((25 \text{ ns} - 12.5 \text{ ns}) - 10 \text{ ns})$, where 10 ns is the iRDY assertion or deassertion set up time (TRDYSU) where the iRDY signal may be asserted. Figure 9 on page 29 shows where iRDY is actually sampled when trying to stall the data phase. iRDY should be deasserted after the next falling edge of EPICLK. iRDY could be erroneously sampled high if it is deasserted at the dotted line.

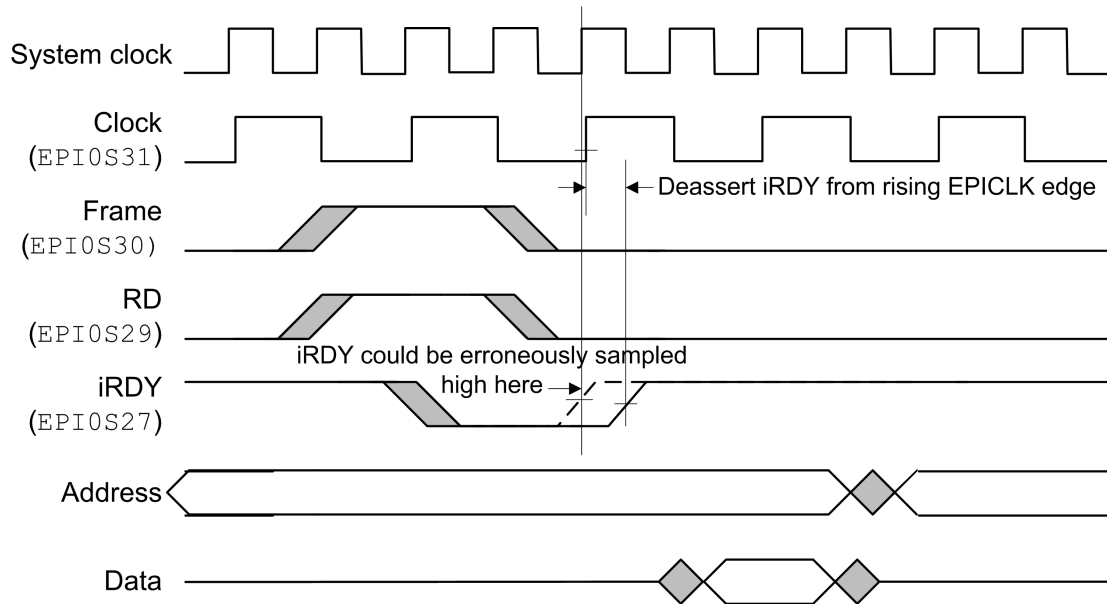
Figure 9. iRDY Timing**Silicon Revision Affected:**

A1, A2

Fixed:

Not yet fixed.

8 General-Purpose Timers

8.1 The General-Purpose Timer match register does not function correctly in 32-bit mode

Description:

The **GPTM Timer A Match (GPTMTAMATCHR)** register triggers a match interrupt and a DMA request, if enabled, when the lower 16 bits match, regardless of the value of the upper 16 bits.

Workaround:

None.

Silicon Revision Affected:

A1, A2

Fixed:

Not yet fixed.

8.2 A spurious DMA request is generated when the timer rolls over in Input-Edge Time mode

Description:

When the timer is in Input-Edge Time mode and rolls over after the terminal count, a spurious DMA request is generated.

Workaround:

Either ignore the spurious interrupt, or capture the edge time into a buffer via DMA, then the spurious interrupt can be detected by noting that the captured value is the same as the previous capture value.

Silicon Revision Affected:

A1, A2

Fixed:

Not yet fixed.

8.3 A spurious DMA request is generated when the timer rolls over the 16-bit boundary

Description:

When the timer is in 32-bit periodic or one-shot mode and is enabled to generate periodic DMA requests, a spurious DMA request is generated when the timer rolls past 0x0000FFFF.

Workaround:

Only use DMA with a 16-bit periodic timer.

Silicon Revision Affected:

A1, A2

Fixed:

Not yet fixed.

8.4 The value of the prescaler register is not readable in Edge-Count mode

Description:

In Edge-Count mode, the prescaler is used as an 8-bit high order extension to the 16-bit counter. When reading the **GPTM Timer n (GPTMTnR)** register as a 32-bit value, the bits [23:16] always contain the initial value of the **GPTM Timer n Prescale (GPTMTnPR)** register, that is, the "load" value of the 8-bit extension.

Workaround:

None.

Silicon Revision Affected:

A1, A2

Fixed:

Not yet fixed.

8.5 ADC trigger and Wait-on-Trigger may assert when the timer is disabled

Description:

If the value in the **GPTM Timer n Match (GPTMTnMATCHR)** register is equal to the value of the timer counter and the **TnOTE** bit in the **GPTM Control (GPTMCTL)** register is set, enabling the ADC trigger, the trigger fires even when the timer is disabled (the **TnEN** bit in the **GPTMCTL** register is clear). Similarly, if the value in the **GPTMTnMATCHR** register is equal to the value of the timer counter and the **TnWOT** bit in the **GPTM Timer n Mode (GPTMTnMR)** register is set, enabling the Wait-on-Trigger mode, the trigger fires even when the timer is disabled.

Workaround:

Enable the timer before setting the **TnOTE** bit. Also, for the Wait-on-Trigger mode, ensure that the timers are configured in the order in which they will be triggered.

Silicon Revision Affected:

A1, A2

Fixed:

Not yet fixed.

8.6 Wait-on-Trigger does not assert unless the TnOTE bit is set

Description:

Wait-on-Trigger does not assert unless the **TnOTE** bit is set in the **GPTMCTL** register.

Workaround:

If the **TnWOT** bit in the **GPTM Timer n Mode (GPTMTnMR)** register is set, enabling the Wait-on-Trigger mode, the **TnOTE** bit must also be set in the **GPTMCTL** register in order for the Wait-on-Trigger to fire. Note that when the **TnOTE** bit is set, the ADC trigger is also enabled.

Silicon Revision Affected:

A1, A2

Fixed:

Not yet fixed.

8.7 Do not enable match and timeout interrupts in 16-bit PWM mode

Description:

16-bit PWM mode generates match and timeout interrupts in the same manner as periodic mode.

Workaround:

Ensure that any unwanted interrupts are masked in the **GPTMTnMR** and **GPTMIMR** registers.

Silicon Revision Affected:

A1, A2

Fixed:

Not yet fixed.

8.8 Do not use μ DMA with 16-bit PWM mode

Description:

16-bit PWM mode generates match and timeout μ DMA triggers in the same manner as periodic mode.

Workaround:

Do not use μ DMA to transfer data when the timer is in 16-bit PWM mode.

Silicon Revision Affected:

A1, A2

Fixed:

Not yet fixed.

8.9 Writing the GPTMTnV register does not change the timer value when counting up

Description:

When counting up, writes to the **GPTM Timer n Value (GPTMTnV)** register do not change the timer value.

Workaround:

None.

Silicon Revision Affected:

A1, A2

Fixed:

Not yet fixed.

8.10 The prescaler does not work correctly when counting up in periodic or one-shot mode

Description:

When counting up, the prescaler does not work correctly in 16-bit periodic or snap-shot mode.

Workaround:

Do not use the prescaler when counting up in 16-bit periodic or snap-shot mode.

Silicon Revision Affected:

A1, A2

Fixed:

Not yet fixed.

8.11 Snapshot must be enabled in both Timer A and B when in 32-bit snapshot mode

Description:

When a periodic snapshot occurs in 32-bit periodic mode, only the lower 16-bit are stored into the **GPTM Timer A (GPTMTAR)** register.

Workaround:

If both the `TASNAPS` and `TBSNAPS` bits are set in the **GPTM Timer A Mode (GPTMTAMR)** register, the entire 32-bit snapshot value is stored in the **GPTMTAR** register.

Silicon Revision Affected:

A1, A2

Fixed:

Not yet fixed.

9 Watchdog Timers

9.1 Watchdog clear mechanism described in the data sheet does not work for the Watchdog Timer 1 module

Description:

Periodically reloading the count value into the **Watchdog Timer Load (WDTLOAD)** register of the Watchdog Timer 1 module will not restart the count, as specified in the data sheet.

Workaround:

Disable the Watchdog Timer 1 module before reprogramming the counter. Alternatively, clear the watchdog interrupt status periodically outside of the interrupt handler by writing any value to the **Watchdog Interrupt Clear (WDTICR)** register.

Silicon Revision Affected:

A1, A2

Fixed:

Not yet fixed.

9.2 Watchdog Timer 1 module asserts reset signal even if not programmed to reset

Description:

Even if the reset signal is not enabled (the `RESEN` bit of the **Watchdog Control (WDTCTL)** register is clear), the Watchdog Timer 1 module will assert a reset signal to the system when the time-out value is reached for a second time.

Workaround:

Clear the Watchdog Timer 1 interrupt once the time-out value is reached for the first time by writing any value to the **Watchdog Interrupt Clear (WDTICR)** register.

Silicon Revision Affected:

A1, A2

Fixed:

Not yet fixed.

9.3 **WDTLOAD yields an incorrect value when read back**

Description:

If the Watchdog Timer 1 module is enabled and configured to run off the PIOSC, writes to the **Watchdog Load (WDTLOAD)** register yield an incorrect value when read back.

Workaround:

None.

Silicon Revision Affected:

A1, A2

Fixed:

Not yet fixed.

10 **ADC**

10.1 **The encoding of the VREF field in the ADCCTL register is incorrect**

Description:

The encoding of the `VREF` field in the **ADC Control (ADCCTL)** register is incorrect.

Workaround:

Use `VREF = 0x3` to select the external voltage reference `VREFA`. Use `VREF = 0x1` to select the external voltage reference `VREFA/3`.

Silicon Revision Affected:

A1, A2

Fixed:

Not yet fixed.

10.2 **ADC errors exceed specifications**

Description:

The error for INL, DNL and Gain for the ADC units exceeds specifications. The error values are shown in Table 3 on page 35.

Table 3. ADC Error Value

Parameter	12-bit mode	10-bit mode
INL	16	4
DNL	8	4
Gain	120	30

Workaround:

See Application Note 01282, "Stellaris ADC Calibration" for information on how to adjust for error.

Silicon Revision Affected:

A1

Fixed:

Fixed on Rev A2.

10.3 Retriggering a sample sequencer before it has completed the current sequence results in continuous sampling

Description:

Re-triggering a sample sequencer before it has completed its programmed conversion sequence causes the sample sequencer to continuously sample. If interrupts have been enabled, interrupts are generated at the appropriate place in the sample sequence. This problem only occurs when the new trigger is the same type as the current trigger.

Workaround:

Ensure that a sample sequence has completed before triggering a new sequence using the same type of trigger.

Silicon Revision Affected:

A1, A2

Fixed:

Not yet fixed.

10.4 Digital comparator in last step of sequence does not trigger or interrupt

Description:

If a digital comparator that is expected to trigger or interrupt is configured for the last step of a sample sequence with sequence trigger TRIGGER_PROCESSOR, TRIGGER_COMPn, TRIGGER_EXTERNAL, TRIGGER_TIMER, or TRIGGER_PWMn, the trigger or interrupt does not occur. These sequence trigger parameters should not be used when using a sample sequencer configured with only one step and a digital comparator that is expected to trigger or interrupt.

Note: Sample Sequencer 3 can only be configured for a total of one step.

Workaround:

If an extra sequence step is available in a sample sequencer, a dummy sequence step and a dummy digital comparator can be configured as the last step in the sample sequencer.

Silicon Revision Affected:

A1, A2

Fixed:

Not yet fixed.

10.5 Digital comparator interrupts do not trigger or interrupt as expected**Description:**

The digital comparator configured for the ADC sample sequence step (n+1) is triggered if the voltage on the AINx input specified for step (n) meets the conditions that trigger the digital comparator for step (n+1). In this case, the conversion results are sent to the digital comparator specified by step (n+1).

Workaround:

Adjust user code or hardware to account for the fact that the voltage seen at the AINx input specified for sequence step (n) will be handled by sequence step (n+1)'s digital comparator using sequence step (n+1)'s configurations.

Silicon Revision Affected:

A1, A2

Fixed:

Not yet fixed.

10.6 Missing trigger or interrupt when multiple sequences configured for processor trigger and different trigger**Description:**

If a sample sequence is configured to trigger or interrupt using a processor event and a different, consecutive sample sequence is configured to trigger or interrupt using any other event, the interrupt or trigger for the processor-triggered sample sequence will occasionally not occur, even if the processor-triggered sample sequence is configured with a higher priority.

Workaround:

None.

Silicon Revision Affected:

A1, A2

Fixed:

Not yet fixed.

10.7 ADC sample sequencers priorities are different than expected**Description:**

If sample sequencer 2 (SS2) and sample sequencer 3 (SS3) have been triggered, and sample sequencer 0 (SS0) and sample sequencer 1 (SS1) have not been triggered or have already been triggered, the priority control logic compares the priorities of SS1 and SS2 rather than SS2 and SS3.

For example, if SS1's priority is the highest (such as 0) and SS3's priority is higher than SS2's priority (such as SS3 = 1, SS2 = 2), SS2 is incorrectly selected to initiate the sampling conversion after SS1. If SS1's priority is the lowest (such as 3) and SS3's priority is lower than SS2's (such as SS3 = 2, SS2 = 1), SS3 is incorrectly selected as the next sample sequencer, then SS2, then SS1.

Workaround:

If only three of the four ADC sample sequencers are needed, SS0 and SS1 can be used with either SS2 or SS3. This ensures that the execution order is as expected. If all four ADC sample sequencers are needed, the highest priority conversions should be programmed into SS0 and SS1. The sequences programmed into SS2 and SS3 occur, but not necessarily in the programmed priority order.

Silicon Revision Affected:

A1, A2

Fixed:

Not yet fixed.

10.8 Simultaneous sampling on both ADC modules yields incorrect samples

Description:

The input impedance of the analog input channel is altered if both ADC modules are used to sample the same pin at the same time. The altered input impedance results in incorrect samples.

Workaround:

Avoid incorrect samples by performing one of the following:

- Configure the ADC modules to sample at different times.
- Wait twice as long for the sample to settle.
- Halve the input impedance.

Silicon Revision Affected:

A1, A2

Fixed:

Not yet fixed.

10.9 Phase offset does not delay as expected if sample sequencers are not triggered at the same time

Description:

The phase difference set in the **ADC Sample Phase Control (ADCSPC)** register does not reference the same starting point in time if the sequencers are configured for a phase offset and are not triggered at the same time.

Workaround:

Use the same trigger to ensure that the sample sequencers will trigger at the same time. If using processor trigger and both ADC modules with phase offset, use the `GSYNC` and `SYNCWAIT` bits in the **ADC Processor Sample Sequence Initiate (ADCPSSI)** register to ensure that the trigger occurs simultaneously. The phase offsets will not align if triggering using Trigger Always mode.

Silicon Revision Affected:

A1, A2

Fixed:

Not yet fixed.

11 UART

11.1 The RTRIS bit in the UARTRIS register is only set when the interrupt is enabled

Description:

The `RTRIS` (UART Receive Time-Out Raw Interrupt Status) bit in the **UART Raw Interrupt Status (UARTRIS)** register should be set when a receive time out occurs, regardless of the state of the `RTIM` enable bit in the **UART Interrupt Mask (UARTIM)** register. However, currently the `RTIM` bit must be set in order for the `RTRIS` bit to be set when a receive time out occurs.

Workaround:

For applications that require polled operation, the `RTIM` bit can be set while the UART interrupt is disabled in the NVIC using the `IntDisable(n)` function in the StellarisWare Peripheral Driver Library, where `n` is 21, 22, or 49 depending on whether UART0, UART1 or UART2 is used. With this configuration, software can poll the `RTRIS` bit, but the interrupt is not reported to the NVIC.

Silicon Revision Affected:

A1, A2

Fixed:

Not yet fixed.

11.2 LIN mode Sync Break does not have the correct length

Description:

When operating as a LIN master, the microcontroller provides a Sync Break of the length that is programmed in the `BLEN` field in the **UART LIN Control (UARTLCTL)** register. However, the actual Sync Break length is 1 less than what is programmed in the `BLEN` field as shown in Table 4 on page 38.

Table 4. SyncBreak Length

<code>BLEN</code> Encoding	Data Sheet Value	Actual Value
0x0	13T bits	12T bits
0x1	14T bits	13T bits
0x2	15T bits	14T bits

BLE _N Encoding	Data Sheet Value	Actual Value
0x3	16T bits	15T bits

Workaround:

Adjust the BLE_N encoding to correspond to the actual Sync Break required.

Silicon Revision Affected:

A1, A2

Fixed:

Not yet fixed.

11.3 When UART LIN or SIR mode is enabled, μ DMA burst transfer does not occur

Description:

If the LIN or the IrDA Serial Infrared (SIR) mode is enabled in the UART peripheral and the μ DMA UART_n RX or UART_n TX channel is configured to do a burst transfer, the burst data transfer does not occur.

Workaround:

Clear the SET_n bit in the **DMA Channel Useburst Set (DMAUSEBURSTSET)** register to have the μ DMA UART channel respond to single or burst requests to ensure that the data transfer occurs.

Silicon Revision Affected:

A1, A2

Fixed:

Not yet fixed.

11.4 UART transfers fail at certain system clock frequency and baud rate combinations

Description:

UART data transfers using the TXRIS and RXRIS interrupt bits and FIFOs fail for certain combinations of the system clock frequency and baud rate.

System Clock Freq [MHz]	32	24	16	10	8	5	4	2	1
Falling Baud Rate [bps]	<460800	<460800	<230400	<460800	<115200	<230400	<57600	<38400	<19200

Workaround:

Use a system clock frequency above 32MHz if using the UART with the raw interrupt status bits or use μ DMA UART data transfers instead of the TXRIS and RXRIS bits. When using μ DMA UART data transfers, there are no system clock frequency and baud rate conflicts.

Silicon Revision Affected:

A1, A2

Fixed:

Not yet fixed.

12 SSI

12.1 Freescale SPI Mode at low SSIClk frequencies can yield data corruption

Description:

Data transmitted by the SPI slave may be corrupted when using Freescale SPI Mode 0 at an SSIClk frequency between 0.5 MHz to 1.1 MHz and a system clock frequency of 33 MHz or lower.

Workaround:

Operate the Freescale SPI Mode 0 at an SSIClk frequency above 1.1 MHz and use a system clock frequency above 33 MHz or use a different mode.

Silicon Revision Affected:

A1, A2

Fixed:

Not yet fixed.

13 Ethernet Controller

13.1 Encoding error in the Ethernet MAC LED Encoding (MACLED) register

Description:

Configuring the LED0 or LED1 field of the **Ethernet MAC LED Encoding (MACLED)** register to 0x8 should cause the corresponding LED to report a combined link + activity status. However, it instead only reports activity status (i.e. exactly the same as encoding 0x1).

Workaround:

None.

Silicon Revision Affected:

A1, A2

Fixed:

Not yet fixed.

14 USB

14.1 USB compliance test issue: USB full-speed, far-end signal compliance tests fail with 5 m cable

Description:

While USB packet loss has not been observed, the device is unable to pass the following USB compliance tests:

- USB Host Test B.3.3.2 Full-speed Downstream Signal Quality Test
- USB Device Test B.6.3.1 Signal Integrity Test – Upstream Signal test (full speed)

Compliance testing is based on the “USB Implementers Forum Full and Low Speed Electrical and Interoperability Compliance Test Procedure” Revision 1.3 available from usb.org website. The compliance testing is performed using a 5 m USB certified cable between the host or device under test and the test SQiDD which is then connected to a USB compliant hub chain to the root hub. Under compliance test conditions, the rising edges of the USB D+/D- signals begin to violate the lower right corner of the full-speed eye diagram defined by the USB specification. USB certification cannot be obtained because of this erratum.

A full report on this issue, "USB Far End Signal Integrity Test Results," is available from your local TI FAE.

Workaround:

If a cable with a length of 1 m is used instead of a 5 m cable, the Eye diagram compliance tests all pass with adequate margin across the voltage and temperature range of the part. Under nominal voltage and temperature conditions, a cable of up to 3 m can be used and passes the eye diagram compliance tests.

Silicon Revision Affected:

A1

Fixed:

Fixed in Rev A2.

14.2 USB compliance test issue: USB embedded host low-speed, far-end signal compliance tests fail

Description:

While USB packet loss has not been observed, the device is unable to pass the following USB compliance test:

- USB Host Test B.3.3.1 Low-Speed Downstream Signal Quality Test

USB Compliance testing is based on the “USB Implementers Forum Full and Low Speed Electrical and Interoperability Compliance Test Procedure” Revision 1.3 available from usb.org website. The rising and falling edges of the USB D+/D- signals violate the lower half of the low-speed eye diagram defined by the USB specification. This erratum applies only to systems defined as a USB embedded host that support low-speed devices. USB embedded host and OTG systems that support full-speed devices only are not affected by this erratum. USB device systems are full-speed only and thus are not affected by this erratum.

A full report on this issue, "USB Far End Signal Integrity Test Results," is available from your local TI FAE.

Workaround:

None.

Silicon Revision Affected:

A1

Fixed:

Fixed in Rev A2.

14.3 MCU may fail USB certification if the EPI module is operating

Description:

If the EPI module is operating, the USB interface may fail USB certification. Failures have been seen for the eye diagram and jitter (see Figure 10 on page 43). Because of these issues, there is a potential for data corruption on the USB interface when using the USB and EPI at the same time. The risk of data corruption is small, but is dependent on the system design.

The USB hardware senses bit errors in the CRC check for control, interrupt, and bulk transfers. If an error occurs, the host hardware requests a resend of the packet up to three times. The application software could be written to address this error further if needed.

Figure 10. Example of USB Certification Failure

- Signal eye:
Eye Diagram Test fails

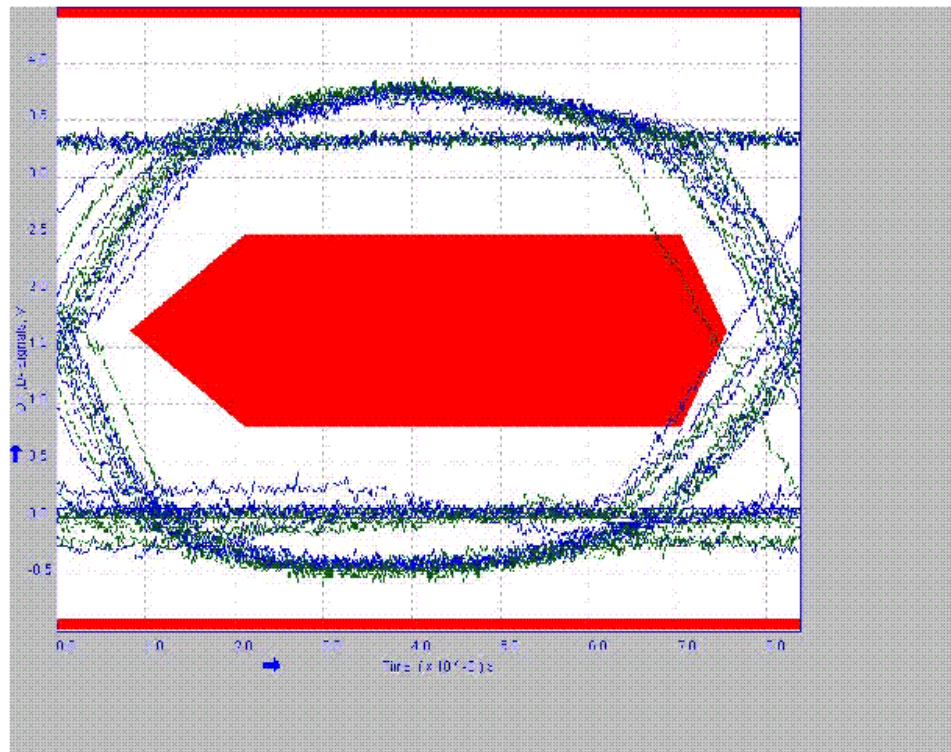

- EOP width: 169.0995ns
EOP width passes
- Receivers: reliable operation on tier Tier 6
Receivers pass
- Measured Signalling Rate: 11.92707Mbps
signal rate conditionally passes
- Crossover voltage range: 1.546667 V to 1.680000 V
Mean crossover = 1.615889 V
First crossover at 1.660000 V(11 other differential crossovers checked)
crossover voltages pass
- Consecutive jitter range: -165.1885ns to 1.811468ns, RMS jitter 52.27256ns
Paired JK jitter range: 752.3810ps to 2.871429ns, RMS jitter 1.821542ns
Paired KJ jitter range: 1.185714ns to 2.168571ns, RMS jitter 1.695397ns
jitter fails

USB certification can be attained if an application does not require the USB and the EPI to be operating simultaneously. Customers who do not intend to pursue USB certification should determine if their application can handle the resulting small amount of error.

Workaround:

None.

Silicon Revision Affected:

A1, A2

Fixed:

Not yet fixed.

14.4 Special considerations for PB1

Description:

When using PB1 as a GPIO or digital alternate function, special considerations are required due to issue “PB1 has permanent internal pull-up resistance” on page 25.

Workaround:

The `DEVMODOTG` and `DEVMOD` bits in the **USB General-Purpose Control and Status (USBGPCS)** register can be used to configure the USB controller to operate only in Host mode or Device mode and allowing `PB0` and `PB1` to be used as GPIOs or digital alternate functions. If both the `DEVMODOTG` and `DEVMOD` bits are set, indicating Device mode, the `USB0VBUS` signal is not driven, therefore the USB VBUS signal must be monitored using a GPIO as an input to detect connect and disconnect. This monitoring must be done with a GPIO other than `PB1`, because `PB1` is not 5-V tolerant. Note that this erratum does not affect devices operating in OTG mode. The `USB0VBUS` signal operates as specified.

In addition, if the USB functionality is not used on the device, in order to be able to use PB1 as a GPIO or digital alternate function, the user application must enable the USB module in the **RCGC2** register, set the `DEVMODOTG` bit, and then disable the USB module again. The restrictions detailed in issue “PB1 has permanent internal pull-up resistance” on page 25 still apply.

Silicon Revision Affected:

A1, A2

Fixed:

Not yet fixed.

14.5 Cannot communicate with a low-speed Device through a hub

Description:

When the USB controller is operating as a Host and a low-speed packet is sent to a Device through a hub, the subsequent Start-of-Frame is corrupted. After a period of time, this corruption causes the USB controller to lose synchronization with the hub, resulting in data corruption.

Workaround:

None.

Silicon Revision Affected:

A1, A2

Fixed:

Fixed on devices with date codes of 1A (October 2011) or later. In addition, the system clock on the MCU must be at least 30 MHz.

Note: To determine the date code of your part, look at the first two characters following the dash on the third line of the part markings (highlighted in red in the following figure). The first number after the dash indicates the last decimal digit of the year. The second character

indicates the month. Therefore, the following example shows a date code of 9B which indicates November 2009.



14.6 USB0DM may be driven after reset

Description:

If the microcontroller is reset while the USB device is connected to an upstream port with the `SOFTCONN` bit set in the **USB Power (USBPOWER)** register, the USB0DM signal is driven to 2 V for 66 μ s after the microcontroller comes out of reset. This activity can appear to be unsolicited traffic to the upstream port. This traffic is generally ignored, but may cause unexpected behavior from the upstream host controller.

Workaround:

If the system can determine that a reset is about to occur, disconnect the USB peripheral by clearing the `SOFTCONN` bit in the **USB Power (USBPOWER)** register prior to resetting the device. If the microcontroller reset is asynchronous, there is no workaround.

Silicon Revision Affected:

A1, A2

Fixed:

Not yet fixed.

15 PWM

15.1 PWM fault latch does not operate correctly

Description:

If the `LATCH` bit is set in the **PWMnCTL** register, the PWM fault condition should be latched until the `INTFAULTn` bit in the **PWMISC** register is cleared. However, the PWM fault signal is not correctly latched and the PWM resumes programmed signalling after the fault condition is removed, regardless of whether the `INTFAULTn` bit is cleared.

Workaround:

Software can effectively address this issue with the addition of a few register writes in the ISR.

1. The **PWMnMINFLTPER** register can be used to ensure that the fault is asserted for a long enough period such that the ISR can be called to implement the workaround.
2. The PWM output can be disabled manually using the `PWMnEN` bit in the **PWMENABLE** register.
3. Software can perform computations to determine if the PWM can be restarted.

4. The `INTFAULTn` bit in the **PWMISC** is cleared by writing a 1 to it.
5. The PWM output can be manually re-enabled using the `PWMnEN` bit in the **PWMENABLE** register.

Note that when using this workaround, the PWM output is disabled manually, which means it does not go to the "pre-programmed" state from various fault registers but instead goes to 0.

Silicon Revision Affected:

A1, A2

Fixed:

Not yet fixed.

16 Electrical Characteristics

16.1 First two ADC samples from the internal temperature sensor must be ignored

Description:

The analog source resistance (R_s) to the ADC from the internal temperature sensor exceeds the specified amount of 500 Ω . This causes a settling time requirement that is longer than the sampling interval to the converter.

Workaround:

Three consecutive samples from the same channel must be taken to accurately sample the internal temperature sensor using the ADC. The first two consecutive samples should be discarded and the third sample can be kept. These consecutive samples cannot be interrupted by sampling another channel.

Silicon Revision Affected:

A1, A2

Fixed:

Not yet fixed.

Copyright © 2008-2013 Texas Instruments Incorporated All rights reserved. Stellaris and StellarisWare are registered trademarks of Texas Instruments Incorporated. ARM and Thumb are registered trademarks and Cortex is a trademark of ARM Limited. Other names and brands may be claimed as the property of others.

Texas Instruments Incorporated
108 Wild Basin, Suite 350
Austin, TX 78746
<http://www.ti.com/lm3s>
<http://www-k.ext.ti.com/sc/technical-support/customer-support-centers.htm>



**TEXAS
INSTRUMENTS**



Cortex
Intelligent Processors by ARM

IMPORTANT NOTICE

Texas Instruments Incorporated and its subsidiaries (TI) reserve the right to make corrections, enhancements, improvements and other changes to its semiconductor products and services per JESD46, latest issue, and to discontinue any product or service per JESD48, latest issue. Buyers should obtain the latest relevant information before placing orders and should verify that such information is current and complete. All semiconductor products (also referred to herein as "components") are sold subject to TI's terms and conditions of sale supplied at the time of order acknowledgment.

TI warrants performance of its components to the specifications applicable at the time of sale, in accordance with the warranty in TI's terms and conditions of sale of semiconductor products. Testing and other quality control techniques are used to the extent TI deems necessary to support this warranty. Except where mandated by applicable law, testing of all parameters of each component is not necessarily performed.

TI assumes no liability for applications assistance or the design of Buyers' products. Buyers are responsible for their products and applications using TI components. To minimize the risks associated with Buyers' products and applications, Buyers should provide adequate design and operating safeguards.

TI does not warrant or represent that any license, either express or implied, is granted under any patent right, copyright, mask work right, or other intellectual property right relating to any combination, machine, or process in which TI components or services are used. Information published by TI regarding third-party products or services does not constitute a license to use such products or services or a warranty or endorsement thereof. Use of such information may require a license from a third party under the patents or other intellectual property of the third party, or a license from TI under the patents or other intellectual property of TI.

Reproduction of significant portions of TI information in TI data books or data sheets is permissible only if reproduction is without alteration and is accompanied by all associated warranties, conditions, limitations, and notices. TI is not responsible or liable for such altered documentation. Information of third parties may be subject to additional restrictions.

Resale of TI components or services with statements different from or beyond the parameters stated by TI for that component or service voids all express and any implied warranties for the associated TI component or service and is an unfair and deceptive business practice. TI is not responsible or liable for any such statements.

Buyer acknowledges and agrees that it is solely responsible for compliance with all legal, regulatory and safety-related requirements concerning its products, and any use of TI components in its applications, notwithstanding any applications-related information or support that may be provided by TI. Buyer represents and agrees that it has all the necessary expertise to create and implement safeguards which anticipate dangerous consequences of failures, monitor failures and their consequences, lessen the likelihood of failures that might cause harm and take appropriate remedial actions. Buyer will fully indemnify TI and its representatives against any damages arising out of the use of any TI components in safety-critical applications.

In some cases, TI components may be promoted specifically to facilitate safety-related applications. With such components, TI's goal is to help enable customers to design and create their own end-product solutions that meet applicable functional safety standards and requirements. Nonetheless, such components are subject to these terms.

No TI components are authorized for use in FDA Class III (or similar life-critical medical equipment) unless authorized officers of the parties have executed a special agreement specifically governing such use.

Only those TI components which TI has specifically designated as military grade or "enhanced plastic" are designed and intended for use in military/aerospace applications or environments. Buyer acknowledges and agrees that any military or aerospace use of TI components which have **not** been so designated is solely at the Buyer's risk, and that Buyer is solely responsible for compliance with all legal and regulatory requirements in connection with such use.

TI has specifically designated certain components as meeting ISO/TS16949 requirements, mainly for automotive use. In any case of use of non-designated products, TI will not be responsible for any failure to meet ISO/TS16949.

Products

Audio	www.ti.com/audio
Amplifiers	amplifier.ti.com
Data Converters	dataconverter.ti.com
DLP® Products	www.dlp.com
DSP	dsp.ti.com
Clocks and Timers	www.ti.com/clocks
Interface	interface.ti.com
Logic	logic.ti.com
Power Mgmt	power.ti.com
Microcontrollers	microcontroller.ti.com
RFID	www.ti-rfid.com
OMAP Applications Processors	www.ti.com/omap
Wireless Connectivity	www.ti.com/wirelessconnectivity

Applications

Automotive and Transportation	www.ti.com/automotive
Communications and Telecom	www.ti.com/communications
Computers and Peripherals	www.ti.com/computers
Consumer Electronics	www.ti.com/consumer-apps
Energy and Lighting	www.ti.com/energy
Industrial	www.ti.com/industrial
Medical	www.ti.com/medical
Security	www.ti.com/security
Space, Avionics and Defense	www.ti.com/space-avionics-defense
Video and Imaging	www.ti.com/video

TI E2E Community

e2e.ti.com