



Panel mounting type
One-touch installation type



Panel mounting type
Installation frame type



PC board mounting type

Features

1. 8.7 mm Character Height (previously 7 mm .343 inch)

Easy-to-read character height increased from 7 mm to 8.7 mm .276 inch to .343 inch.



2. Plenty of Digits



3. Select by switch between two time ranges in a single meter.

0 to 999999.9h/0 to 3999d23.9h switchable
0 to 999h59m59s/0 to 9999h59.9m switchable

4. Panel Mounting Type Features 2 Installation Methods

Comes with very easy one-touch installation type and also installation frame type that uses the frame on the timer/counter. Choose a method that suits the application.

5. Battery Replacement Easy on Environment

To replace battery simply remove body for the one-touch installation type, and remove battery lid for the installation frame type.

6. Screw Terminals Designed for Safety

Built in finger protection.

7. Panel Covers Replacable (Standard color is ash gray.)

Change the panel design by replacing with a black panel cover.

8. Conforms to IP66 Protective Construction (Only installation frame type.) (Front panel surface)

9. Input Methods

- 1) Non-voltage input method
- 2) Voltage input method
- 3) Free voltage input method

10. Backlight Type Added to Series and Now 2-color Switchable (green/red)

Easy viewing even in dark places and switchable between green and red (Voltage input type).

11. Compliant with UL, c-UL and CE marking.

RoHS Directive compatibility information
<http://www.nais-e.com/>

Product chart

Type		Standard type			Backlight type
		Non-voltage input type	Voltage input type (4.5 to 30 V DC)	Free voltage input type (24 to 240 V AC/DC)	Voltage input type (4.5 to 30 V DC)
Installation type	One-touch installation type	○	○	○	○
	Installation frame type	○	○	○	○
PC board mounting type		○	—	—	—

Product types

1. Panel mounting type

1) One-touch installation type

① Standard type

No. digits	Measurement time range	Front reset	Input method	Part No.
7 digits	0 to 999999.9h/0 to 3999d23.9h switchable	Yes	Non-voltage input type	LH2H-FE-DHK
	0 to 999h59m59s/0 to 9999h59.9m switchable			LH2H-FE-HMK
	0 to 999999.9h/0 to 3999d23.9h switchable		Voltage input type (4.5 to 30 V DC)	LH2H-FE-DHK-DL
	0 to 999h59m59s/0 to 9999h59.9m switchable			LH2H-FE-HMK-DL
	0 to 999999.9h/0 to 3999d23.9h switchable		Free voltage input type (24 to 240 V AC/DC)	LH2H-FE-DHK-FV
	0 to 999h59m59s/0 to 9999h59.9m switchable			LH2H-FE-HMK-FV

② Backlight type

No. digits	Measurement time range	Front reset	Input method	Part No.
7 digits	0 to 999999.9h/0 to 3999d23.9h switchable	Yes	Voltage input type (4.5 to 30 V DC)	LH2H-FE-DHK-DL-B
	0 to 999h59m59s/0 to 9999h59.9m switchable			LH2H-FE-HMK-DL-B

2) Installation frame type

① Standard type

No. digits	Measurement time range	Front reset	Input method	Part No.
7 digits	0 to 999999.9h/0 to 3999d23.9h switchable	Yes	Non-voltage input type	LH2H-F-DHK
	0 to 999h59m59s/0 to 9999h59.9m switchable			LH2H-F-HMK
	0 to 999999.9h/0 to 3999d23.9h switchable		Voltage input type (4.5 to 30 V DC)	LH2H-F-DHK-DL
	0 to 999h59m59s/0 to 9999h59.9m switchable			LH2H-F-HMK-DL
	0 to 999999.9h/0 to 3999d23.9h switchable		Free voltage input type (24 to 240 V AC/DC)	LH2H-F-DHK-FV
	0 to 999h59m59s/0 to 9999h59.9m switchable			LH2H-F-HMK-FV

② Backlight type

No. digits	Measurement time range	Front reset	Input method	Part No.
7 digits	0 to 999999.9h/0 to 3999d23.9h switchable	Yes	Voltage input type (4.5 to 30 V DC)	LH2H-F-DHK-DL-B
	0 to 999h59m59s/0 to 9999h59.9m switchable			LH2H-F-HMK-DL-B

2. PC board mounting type

No. digits	Measurement time range	Front reset	Input method	Part No.
7 digits	0 to 999999.9h	No	Non-voltage input type	LH2H-C-H-N
	0 to 9999h59.9m			LH2H-C-HM-N

Specifications

1. Panel mounting type

Item	Type	Standard type		Backlight type	Standard type
		Non-voltage input	Voltage input		Free voltage type
No. digits		7 digits			
External power supply		Not required (built-in battery)			
Measurement time range		0 to 999999.9h/0 to 3999d23.9h (Switchable by switch) 0 to 999h59m59s/0 to 9999h59.9m (Switchable by switch) Separate product type			
Start input	Min. input signal width	200 ms			
	Input method (signal)	Non-voltage input using contacts or open collector connection	High level: 4.5 to 30 V DC Low level: 0 to 2 V DC		High level: 24 to 240 V AC/DC Low level: 0 to 2.4 V AC/DC
	Input impedance	When shorted: Max. 10 k Ω When open: Max. 750 k Ω	Approx. 4.7 k Ω		—
	Residual voltage	Max. 0.5 V	—		—
Reset input	Min. input signal width	100 ms			
	Input method (signal)	Non-voltage input using contacts or open collector connection	High level: 4.5 to 30 V DC Low level: 0 to 2 V DC		Non-voltage input using contacts or open collector connection
	Input impedance	When shorted: Max. 10 k Ω When open: Max. 750 k Ω	Approx. 4.7 k Ω		When shorted: Max. 10 k Ω When open: Max. 750 k Ω
	Residual voltage	Max 0.5 V	—		Max. 0.5 V
Display method		7-segment LCD		7-segment LCD With green/red backlight	7-segment LCD
Breakdown voltage (initial)		Between charged and uncharged parts: 1,000 V AC for 1 minute.			Between charged and uncharged parts: 2,000 V AC for 1 minute.
Insulation resistance (initial)		Min. 100 M Ω (measured at 500 V DC) Measurement location same as for break down voltage.			
Backlight power		—		24 V DC (\pm 10%)	—
Protective construction (Note)		IEC Standard IP66 (only panel front: when using rubber gasket)			
Accessories (Note)		Rubber gasket, mounting bracket			
Battery life		10 years (at 25°C 77°F)			

Note) Only for installation frame type.

LH2H

2. PC board mounting type

Item		Type	PC board mounting type
Input method			Non DC voltage input
No. digits			7 digits
Rated operation voltage			3 V DC
Allowable operation voltage range			2.7 to 3.3 V DC
Current consumption			Max. 20 μ A (max. 200 μ A during reset input)
Measurement time range		0 to 999999.9h	0 to 9999h59.9m
Start input	Min. input signal width		200 ms
	Input method		Non-voltage input using contacts or open collector connection
	Input impedance		When shorted: Max. 10 k Ω When open: Max. 750 k Ω
	Residual voltage		Max. 0.5 V
Reset input	Min. input signal width		10 ms
	Input method		Non-voltage input using contacts or open collector connection
	Input impedance		When shorted: Max. 10 k Ω When open: Max. 750 k Ω
	Residual power		Max. 0.5 V
Break down voltage (initial)			Between charged and uncharged parts: 1,000 V AC for 1 minute.
Insulation resistance (initial)			Min. 100 M Ω (measured at 500 V DC) Measurement location same as for break down voltage.

3. Common

Item		Type	Panel mounting/PC board mounting types
Time accuracy			\pm 100 ppm (25°C 77°F)
Vibration resistance	Functional		10 to 55 Hz (1 cycle/min.), single amplitude: 0.15 mm (10 min. on 3 axes)
	Destructive		10 to 55 Hz (1 cycle/min.), single amplitude: 0.375 mm (1 hr. on 3 axes)
Shock resistance	Functional		Min. 98 m/s ² (4 times on 3 axes)
	Destructive		Min. 294 m/s ² (5 times on 3 axes)
Operation temperature			-10 to +55°C +14 to +131°F (without frost or dew)
Storage temperature			-25 to +65°C -13 to +149°F (without frost or dew)
Ambient humidity			35 to 85% RH (non-condensing)

Applicable standard

Safety standard	EN61010-1	Pollution Degree 2/Overvoltage Category III
EMC	(EMI)EN61000-6-4 Radiation interference electric field strength	EN55011 Group1 ClassA
	Noise terminal voltage	EN55011 Group1 ClassA
	(EMS)EN61000-6-2 Static discharge immunity	EN61000-4-2 4 kV contact 8 kV air
	RF electromagnetic field immunity	EN61000-4-3 10 V/m AM modulation (80 MHz to 1 GHz) 10 V/m pulse modulation (90 MHz)
	EFT/B immunity	EN61000-4-4 2 kV (power supply line)
	Conductivity noise immunity	EN61000-4-6 10 V/m AM modulation (0.15 MHz to 80 MHz)
Power frequency magnetic field immunity	EN61000-4-8 30 A/m (50 Hz)	

Part names

1. Front reset button

Reset the elapsed time. It does not work when the lock switch is ON. Be aware that battery life will decrease if this switch is used frequently.

2. Lock switch (Refer to chart on right.)

Disable the front reset button.

Note) Turn ON at the LCD side (reset disabled) and OFF at the terminal block side (reset enabled).

3. Time range switch (See chart on right).

Switch the time range.

Note) Always press the front reset button when operating the time range switch.

4. Time unit sticker

Unit seals are included in the package. Affix them in accordance with the time range.

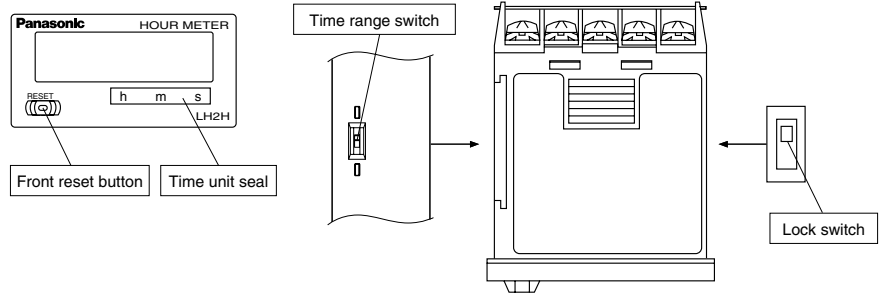

	0 to 999999.9h/0 to 3999d23.9h	0 to 999h59m59s/0 to 9999h59.9m
Lock switch (Unit display 1)	(Terminal block side) OFF* ↕ (LCD side) ON	(Terminal block side) OFF* ↕ (LCD side) ON
Count speed switch (Unit display 2)	(Terminal block side) 0 to 999999.9h* ↕ (LCD side) 0 to 3999d23.9h	(Terminal block side) 0 to 9999h59.9m* ↕ (LCD side) 0 to 999h59m59s

Notes) 1. *Default setting when shipped.
2. Make the switch setting before installing to panel.

Dimensions

1. Panel mounting type

• External dimensions

1) One-touch installation type

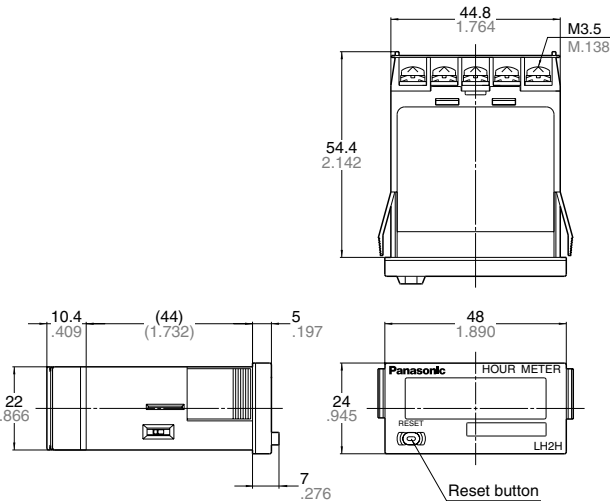

mm inch

General tolerance: ±1.0 ±.039

• Panel installation diagram

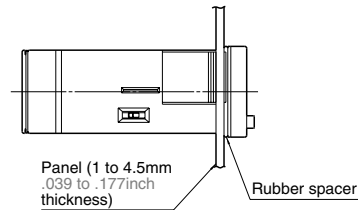

Note) When installing to a 4.5 mm .177 inch thick panel, remove the rubber spacer first.

When installing the one-touch installation type model, make sure that the installation spring does not pinch the rubber gasket.

To prevent the installation spring from pinching the rubber gasket:

1. Set the rubber gasket on both ends of the installation spring (left and right).
2. Confirm that the installation spring is not pinching the rubber gasket, and then insert and fix the installation spring in place from the rear of the timer unit.

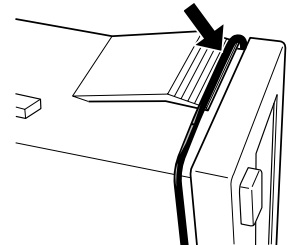

LH2H

2) Installation frame type

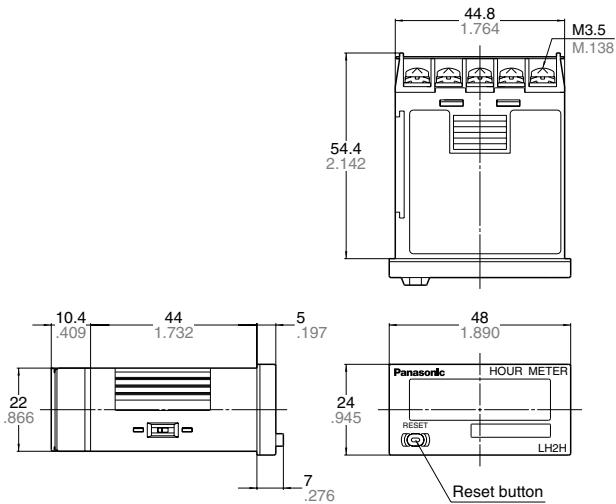

• Panel mounting diagram

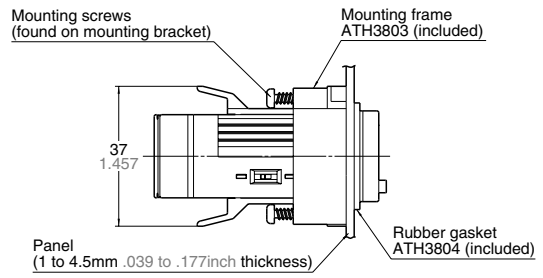

• Panel cut-out dimensions

The standard panel cut-out is shown below.
Use the mounting frame (ATH3803) and the rubber packing (ATH3804).
(Only installation frame type.)

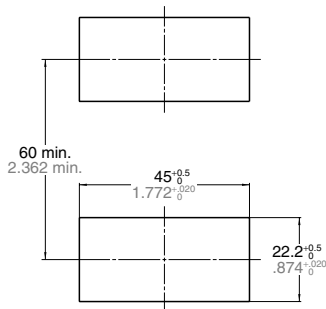

• For connected installation (sealed installation) (Only installation frame type.)

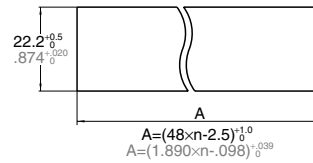

Notes) 1. Suitable installation panel thickness is 1 to 4.5 mm .039 to .177 inch.
2. Waterproofing will be lost when installing repeatedly (sealed installation).

• Terminal layout and wiring diagrams

1) Standard type

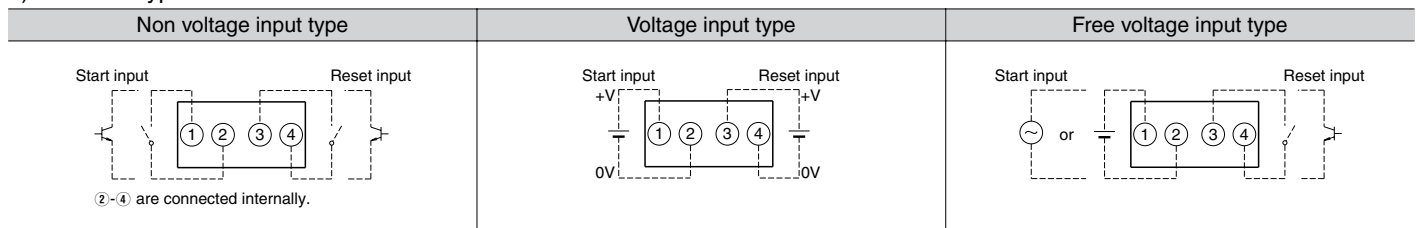

2) Backlight type

Voltage input type

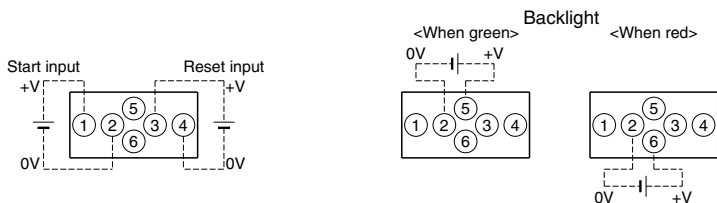

2. PC board mounting type

General tolerance: $\pm 1.0 \pm 0.039$ mm inch

• External dimensions

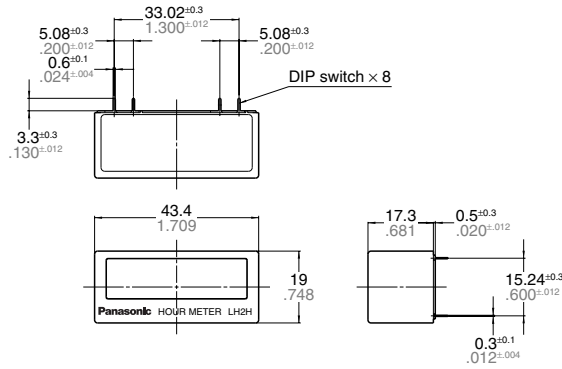

PC board pattern (BOTTOM VIEW)

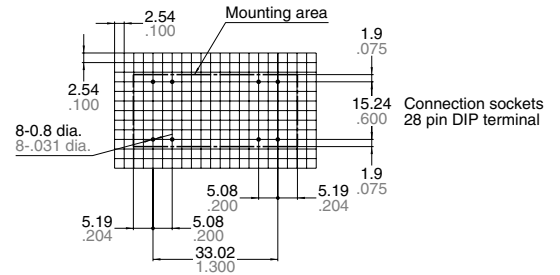

General tolerance: $\pm 0.1 \pm 0.004$

• Terminal layout and wiring diagrams

Note: The AXS212811K is recommended as a compatible connection socket.

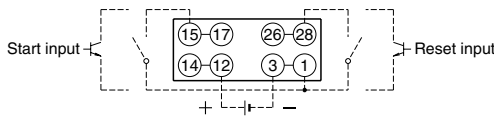

①-③, ⑫-⑭, ⑮-⑰ and ⑳-㉘ are connected internally.
An external power supply is required.

Input method

1. Standard type

Non-voltage input type			
Panel mounting type		PC board mounting type	
Contact input	Transistor input NPN transistor	Contact input	Transistor input NPN transistor

Notes) 1. When using contact input, since current flow is small from terminals ① and ③ on the panel mounting type and terminals ⑮ to ⑰ and ⑳ to ㉘ on the PC board mounting type, please use relays and switches with high contact reliability.
2. When using transistor input, use the following as a guide for which transistors (Tr) to use for inputting. (Collector withstand voltage ≥ 50 V, leakage current $< 1 \mu\text{A}$)

Voltage input type			Free voltage input type
Contact input	Transistor input		
	NPN transistor	PNP transistor	

Notes) 1. ② and ④. (The input and reset circuits are functionally insulated.)
2. When using transistor (Tr) input, use the right as a guide. (Collector withstand voltage ≥ 50 V, leakage current $< 1 \mu\text{A}$)
3. Be aware that the application of voltage that exceeds the voltage range of the H level to the count input terminal, and the application of voltage to the reset input terminal, can cause damage to the internal elements.

LH2H

2. Backlight type

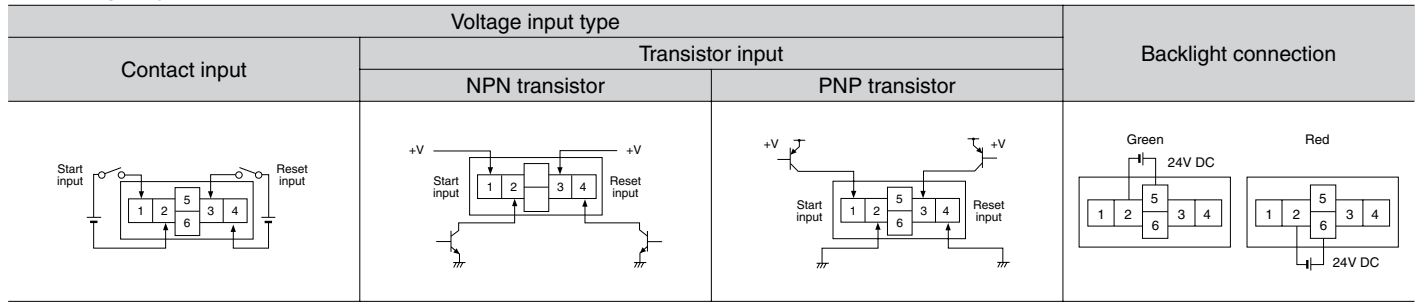

- Notes)
- Do not reverse the polarities when connecting the DC voltage for the backlight.
 - ② and ④. (The input and reset circuits are functionally insulated.)
 - When using transistor (Tr) input, use the right as a guide. (Collector withstand voltage ≥ 50 V, leakage current $< 1 \mu\text{A}$)
 - Be aware that the application of voltage that exceeds the voltage range of the H level to the count input terminal, and the application of voltage to the reset input terminal, can cause damage to the internal elements.

Explanation of operation

- Time measuring takes place when the start input is ON.
- When the elapsed (measured) time reaches full scale it returns to "0", and then measuring starts again from "0".
- When reset input is ON, the display becomes "0". You cannot measure during reset input.

For PC board mounting type the display disappears while the reset input is ON; however, the display reads "0" when the reset input turns OFF.

- Press the front reset button if you want to perform a manual reset (for panel installation type)

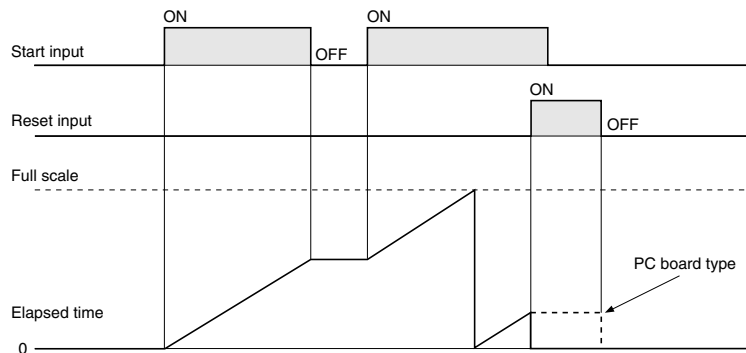

Cautions for use

1. Non-voltage input type

For both panel mounting and PC board mounting types

1) Never apply voltage to the non-voltage input type. This will damage the internal elements.

2) Since the current flow is very small from the start input and reset input terminals (① and ③ on the panel mounting type and terminals ⑮ to ⑰ and ⑳ to ㉔ on the PC board mounting type) please use relays and switches with high contact reliability. When inputting with an open collector of a transistor, use a transistor for small signals in which ICBO is 1 μ A or less and always input with no voltage.

3) When wiring, try to keep all the input lines to the start and reset inputs as short as possible and avoid running them together with high voltage and power transmission lines or in a power conduit. Also, malfunctions might occur if the floating capacitance of these wires exceeds 500 pF (10 m 32.808 ft. for parallel wires of 2 mm²). In particular, when using shielded wiring, be careful of the capacitance between wires.

PC board mounting type

1) For external power supply use manganese dioxide or lithium batteries (CR type: 3V).

2) Always reset after external power is applied and confirm that the display reads "0".

3) Make the wiring from the battery to the hour meter unit as short as absolutely possible. Also, be careful of polarity.

4) Calculate battery life with the following formula.

$$t = A/I$$

t: battery life [h]

I: LH2H current consumption [mA]

A: battery capacity until minimum operation voltage is reached [mAh]

5) Hand solder to the lead terminal. Do not dip solder. With the tip of the soldering iron at 300°C 572°F perform soldering within 3 seconds (for 30 to 60 W soldering iron).

2. Voltage input type

1) Be aware that applying more than 30 V DC to start input terminals ① and ②, and reset input terminals ③ and ④ will cause damage to the internal elements.

2) For external resetting use H level (application of 4.5 to 30 V DC) between reset terminals ③ and ④ of the rear terminals. In this case, connect + to terminal ③ and - to terminal ④. This is the valid polarity; therefore, the hour meter will not work if reversed.

3) When wiring, try to keep all the input lines to the start and reset inputs as short as possible and avoid running them together with high voltage and power transmission lines or in a power conduit. Also, malfunctions might occur if the floating capacitance of these wires exceeds 500 pF (10 m 32.808 ft. for parallel wires of 2 mm²).

3. Free voltage input type

1) Use start input terminals ① and ② for free voltage input and reset terminals ③ and ④ for non-voltage input.

2) Be aware that the application of voltage that exceeds the voltage range of the H level to the start input terminal, and the application of voltage to the reset input terminal, can cause damage to the internal elements.

3) Since the current flow is very small from reset input terminal ③, please use relays and switches with high contact reliability.

4) When inputting a reset with an open collector of a transistor, use a transistor for small signals in which ICBO is 1 μ A or less and always input with no voltage.

5) To reset externally, short reset input terminals ③ and ④ on the rear.

6) Input uses a high impedance circuit; therefore, erroneous operation may occur if the influence of induction voltage is present. If you plan to use wiring for the input signal that is 10 m or longer (wire capacitance 120 pF/m at normal temperature), we recommend the use of a CR filter or the connection of a bleeder resistor.

4. How to reset multiple panel mounting type counters all at once (input is the same for count)

Non-voltage input type

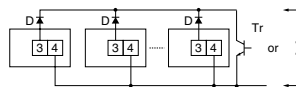

- Notes) 1. Use the following as a guide for choosing transistors used for input (Tr).
Leakage current < 1 μ A
2. Use as small a diode (D) as possible in the forward voltage so that the voltage between terminals 3 and 4 during reset input meets the standard value (0.5 V).
(At IF = 20 μ A, forward voltage 0.1 and higher.)

Voltage input type

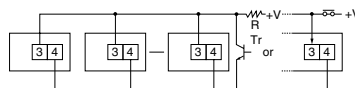

Note) Make sure that H (reset ON) level is at least 4.5 V.

5. Backlight luminance

To prevent varying luminance among backlights when using multiple Backlight types, please use the same backlight power supply.

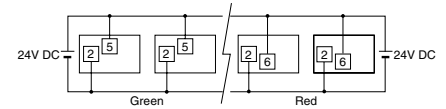

6. Acquisition of CE marking

Please abide by the conditions below when using in applications that comply with EN 61010-1/IEC 61010-1

- 1) Ambient conditions
 - Overvoltage category II, pollution level 2
 - Indoor use
 - Acceptable temperature and humidity range: -10 to +55°C, 35 to 85%RH (with no condensation at 20°C)
 - Under 2000 m elevation
- 2) Use the main unit in a location that matches the following conditions.
 - There is minimal dust and no corrosive gas.
 - There is no combustible or explosive gas.
 - There is no mechanical vibration or impacts.
 - There is no exposure to direct sunlight.
 - Located away from large-volume electromagnetic switches and power lines with large electrical currents.
- 3) Connect a breaker that conforms to EN60947-1 or EN60947-3 to the voltage input section.
- 4) Applied voltage should be protected with an overcurrent protection device (example: T 1A, 250 V AC time lag fuse) that conforms to the EN/IEC standards. (Free voltage input type)

7. Terminal connection

Tighten the terminal screws with a torque of 0.8 N·cm or less.