

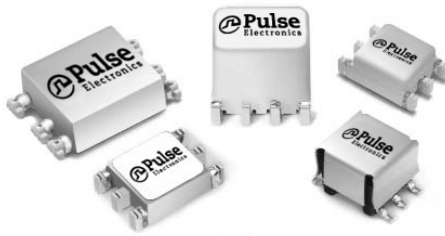



SMT Gate Drive Transformers

>1500V_{DC} Basic and Functional Insulation



-  >1500V_{DC} isolation between Gate and Drive
-  Basic insulation (1.4mm creepage/clearance) and functional available
-  Operating frequency: 50kHz and up

Electrical Specifications @ 25°C - Operating Temperature -40°C to +130°C⁵

Part ^{3,4} Number	Turns Ratio	Pri-Sec Insulation (V _{DC})	MAX ¹ V*μsec	Primary Inductance (μH MIN)	Leakage ² Inductance (μH MAX)	DCR Primary (Ω MAX)	DCR Secondary (Ω MAX)	Package Size (L x W x H) (mm MAX)
Functional Insulation								
PE-68386NL	1:1	1500 Vrms	9.7	785	0.46	0.60	0.60	8.6 x 6.7 x 2.5
PO926NL	1:1:1	1500 Vrms	23.8	300	0.50	2.00	2.00	8.0 x 6.6 x 5.3
P0544NL	1:1:1	1500 Vrms	45.1	3300	0.70	1.60	1.60	9.0 x 8.6 x 7.6
PA0264NL	1:1:1	1500 Vrms	12.7	1140	0.65	0.75	0.75	8.6 x 6.7 x 3.6
PA1323NL	1:1	1500 Vrms	21.7	600	2.0	1.25	1.25	9.5 x 7.0 x 5.3
Basic Insulation (1.4mm creepage and clearance between Primary and Secondary)								
PA0173NL	1:1:1	1500 Vrms	17.2	980	0.75	0.62	0.88	11.8 x 8.8 x 4.0
PA0185NL	1:1	1500 Vrms	17.2	980	0.75	0.88	0.62	11.8 x 8.8 x 4.0
PA0184NL	1:1	1500 Vrms	27.2	1200	0.50	0.91	0.91	9.0 x 8.6 x 7.6
PA0297NL	2:1:1	1500 Vrms	27.2	1200	0.60	0.91	0.46	9.0 x 8.6 x 7.6
PA2777NL	1:1	1500 Vrms	9.3	335.2	0.36	0.70	0.70	7.1 x 6.1 x 5.5
PA0510NL	2.5:1:1	1500 Vrms	27.2	1200	0.68	0.91	0.380	9.0 x 8.6 x 7.6
PA3493NL	1.25:1	1650 Vdc	23	656	1.3	1.03	0.85	10.9 x 9.7 x 2.7

Notes:

1. The Maximum volt-μsec rating limits the peak flux density to 2200 Gauss when used in a unipolar drive application. For bi-polar drive applications, a maximum volt-sec of two times this rating is acceptable (ie: 2* (volt*μsec rating) = (voltage applied to the primary) * dutycycle / Frequency = V * alpha / Freq_Hz = V * μsec
2. Leakage inductance is measured at primary terminals with all secondaries shorted.
3. Optional Tape & Reel packaging can be ordered by adding a "T" suffix to the part number (i.e. P0544NL becomes P0544NLT). Pulse complies to industry standard tape and reel specification EIA481.

4. The "NL" suffix indicates an RoHS-compliant part number. Non-NL suffixed parts are not necessarily RoHS compliant, but are electrically and mechanically equivalent to NL versions. If a part number does not have the "NL" suffix, but an RoHS compliant version is required, please contact Pulse for availability.
5. The temperature of the component (ambient plus temperature rise) must be within the stated operating temperature range.

SMT Gate Drive Transformers

>1500V_{DC} Basic and Functional Insulation

Mechanicals

Schematics

PE-68386NL

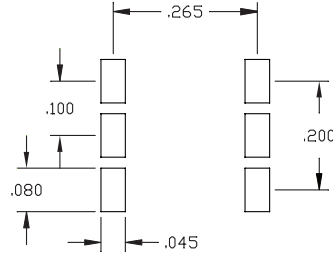
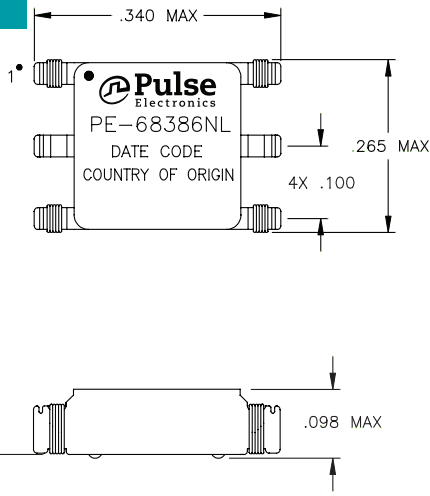

RECOMMENDED PAD LAYOUT

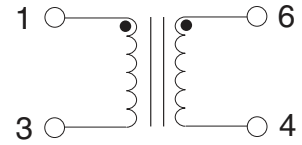

Weight0.28 grams
Tape & Reel1500/reel
Tube60/tube

Dimension: $\frac{\text{Inches}}{\text{mm}}$

Unless otherwise specified, all tolerances are $\pm \frac{.010}{0,25}$

PA0264NL

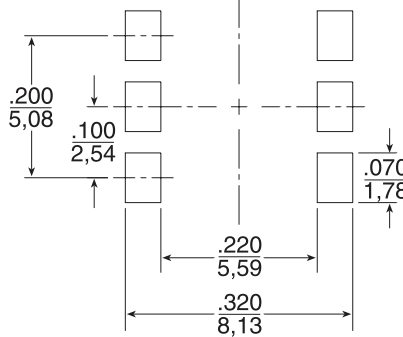
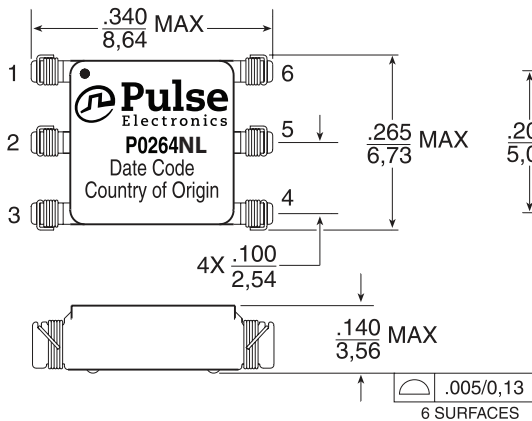

SUGGESTED PAD LAYOUT

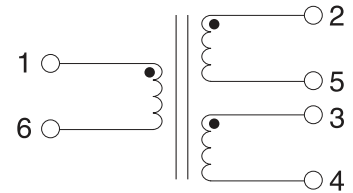

Weight0.28 grams
Tape & Reel1500/reel
Tube60/tube

Dimension: $\frac{\text{Inches}}{\text{mm}}$

Unless otherwise specified, all tolerances are $\pm \frac{.010}{0,25}$

P0926NL

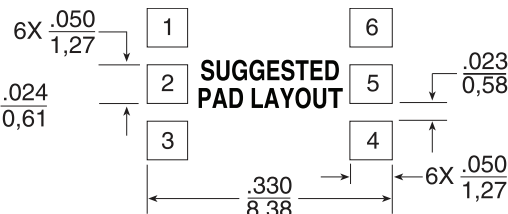
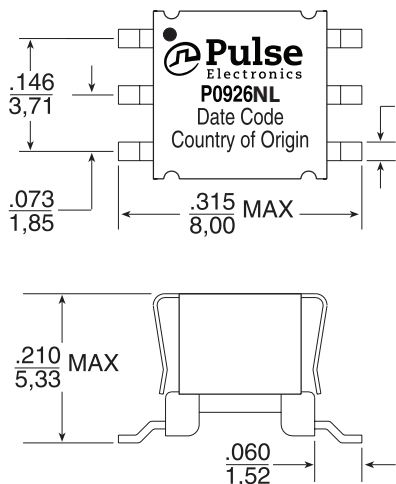

SUGGESTED PAD LAYOUT

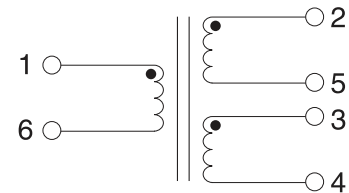

Weight0.48 grams
Tape & Reel1000/reel
Tube80/tube

Dimension: $\frac{\text{Inches}}{\text{mm}}$

Unless otherwise specified, all tolerances are $\pm \frac{.010}{0,25}$

SMT Gate Drive Transformers

>1500V_{DC} Basic and Functional Insulation

Mechanicals (continued)

Schematics

P0544NL, PA0297, PA0510, PA0184NL

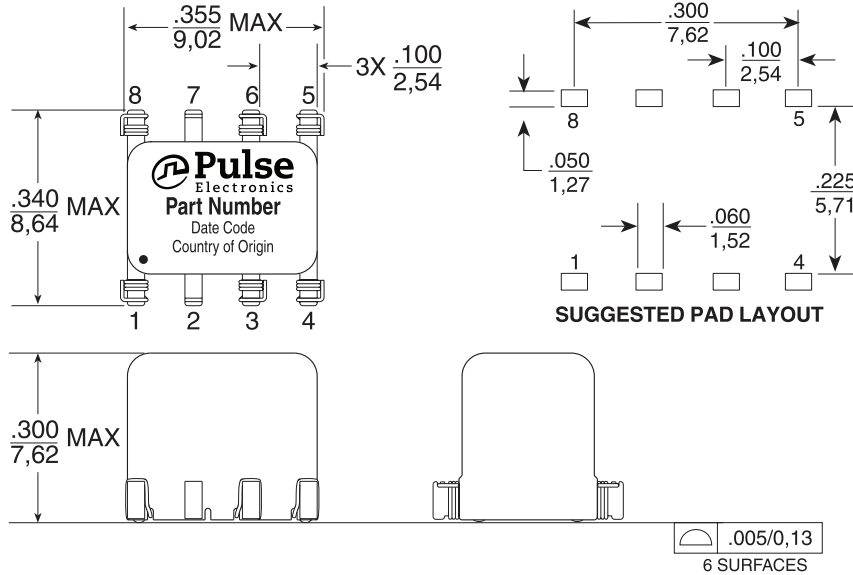

P0544 / PA0297 / PA0510

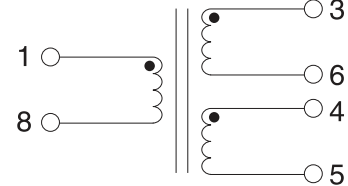

PA0184

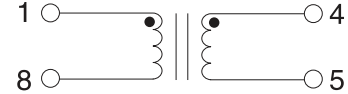

Weight0.60 grams
Tape & Reel40/reel
Tube50/tube

Dimension: $\frac{\text{Inches}}{\text{mm}}$
Unless otherwise specified, all tolerances are $\pm \frac{.010}{0,25}$

PA0173, PA0185

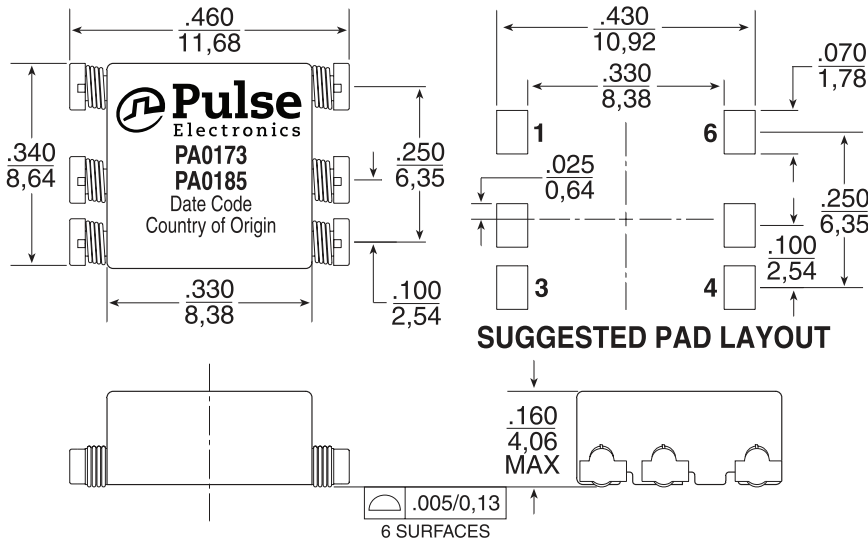

PA0173

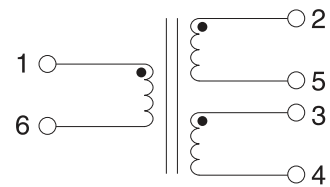

PA0185

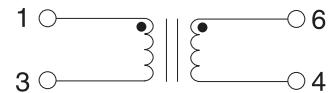

Weight0.48 grams
Tape & Reel900/reel
Tube60/tube

Dimension: $\frac{\text{Inches}}{\text{mm}}$
Unless otherwise specified, all tolerances are $\pm \frac{.010}{0,25}$

SMT Gate Drive Transformers

>1500V_{DC} Basic and Functional Insulation

Mechanicals (continued)

Schematics

PA3493NL

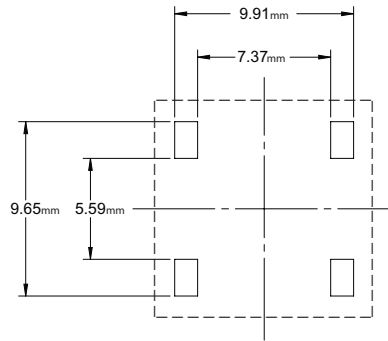
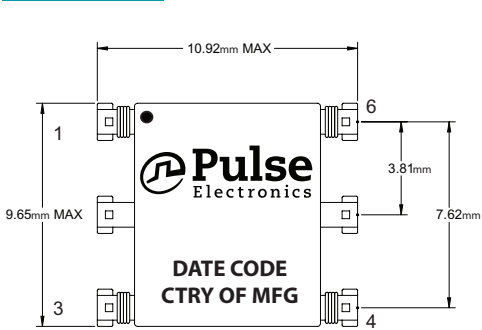

SUGGESTED FOOTPRINT

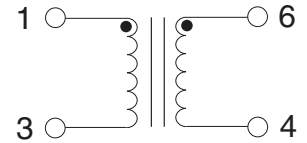
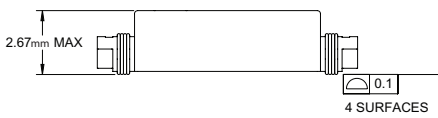

Weight0.31 grams
 Tape & Reel1250/reel
 Tube50/tube

Dimension: mm

Unless otherwise specified, all tolerances are $\pm 0,25$

PA2777NL

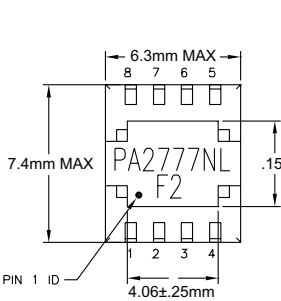

TOP VIEW

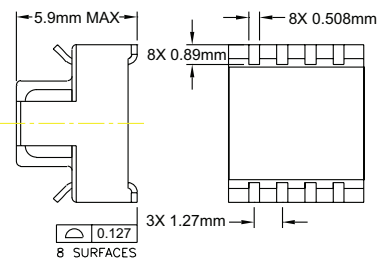

BOTTOM VIEW

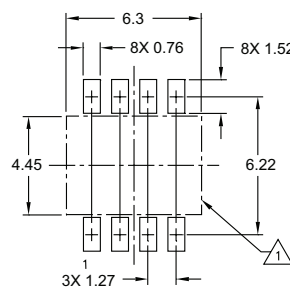

SUGGESTED LAND PATTERN

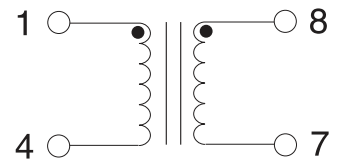

Weight0.32 grams
 Tape & Reel850/reel
 Tube120/tube

Dimension: mm

Unless otherwise specified, all tolerances are $\pm 0,25$

SMT Gate Drive Transformers

>1500V_{DC} Basic and Functional Insulation

Mechanics (continued)

Schematics

PA1323NL

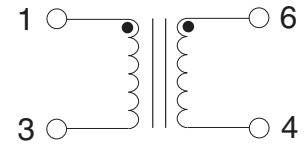
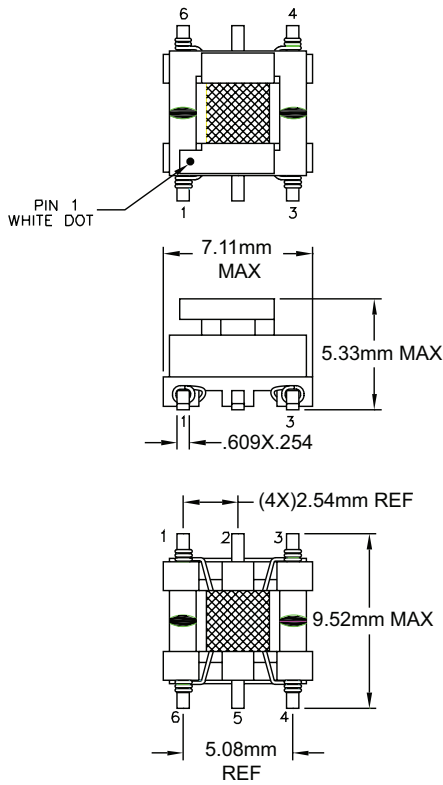

Weight0.4 grams

Tape & Reel700/reel

Tube225/tube

Dimension: mm

Unless otherwise specified, all tolerances are $\pm 0,25$

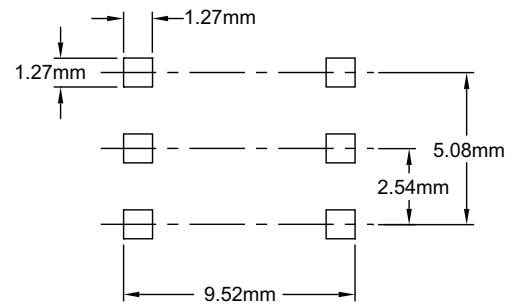

SUGGESTED PCB LAYOUT