

User Guide for
FEBFL7730_L20L008A

8.4W LED Bulb Using FL7730

Featured Fairchild Product:
FL7730

***Direct questions or comments
about this evaluation board to:
“Worldwide Direct Support”***

Fairchild Semiconductor.com

Table of Contents

1. Introduction.....	3
1.1. General Description.....	3
1.2. Features	3
1.3. Internal Block Diagram.....	4
2. General Specifications	5
3. Photographs.....	6
4. Printed Circuit Board	7
5. Schematic.....	8
2.1 Bill of Materials	9
2.2 Transformer and Winding Specifications	10
6. Performance of Evaluation Board.....	11
6.1. Startup	11
6.2. Operation Waveforms	11
6.3. Constant Current Regulation.....	12
6.4. Open/Short-LED Protections	13
6.5. Dimming Operation.....	14
6.6. System Efficiency	17
6.7. Power Factor and THD	17
6.8. Operating Temperature	18
6.9. EMI.....	19
7. Revision History	20



This user guide supports the evaluation kit for the FL7730. It should be used in conjunction with the FL7730 datasheet as well as Fairchild's application notes and technical support team. Please visit Fairchild's website at www.fairchildsemi.com.

1. Introduction

This document describes the proposed solution for low-line voltage LED ballast using the FL7730 PSR single-stage controller. The input voltage range is $90V_{RMS} - 140V_{RMS}$ and there is one DC output with a constant current of 380mA at $22V_{MAX}$. This document contains general description of FL7730, the power supply specification, schematic, bill of materials, and the typical operating characteristics.

1.1. General Description

The FL7730 is an active Power Factor Correction (PFC) controller using single-stage flyback topology. Dimming control with no flicker is implemented by an analog sensing method. Primary-side regulation and single-stage topology reduce external components such as input bulk capacitor and feedback circuitry and minimize cost. To improve good power factor and Total Harmonic Distortion (THD), constant on-time control is utilized with internal error amplifier and a low-bandwidth compensator. Precise constant-current control regulates accurate output current, independent of input voltage and output voltage. Operating frequency is proportionally changed by output voltage to guarantee DCM operation with higher efficiency. FL7730 provides protections such as open-LED, short-LED, and over-temperature protection.

1.2. Features

- Compatible with Traditional TRIAC Control
- Cost-Effective Solution without Input Bulk Capacitor and Feedback Circuitry
- Power Factor Correction (PFC)
- Accurate Constant-Current (CC) Control
- Line Voltage Compensation for CC Control
- Linear Frequency Control for Better Efficiency and Simpler Design
- Open-LED Protection
- Short-LED Protection
- Cycle-by-Cycle Current Limiting
- Over-Temperature Protection with Auto Restart
- Low Startup Current: 20 μ A
- Low Operating Current: 5mA
- Frequency Hopping for EMI
- V_{DD} Under-Voltage Lockout (UVLO)
- Gate Output Maximum Voltage Clamped at 18V
- SOP-8 Package Available

1.3. Internal Block Diagram

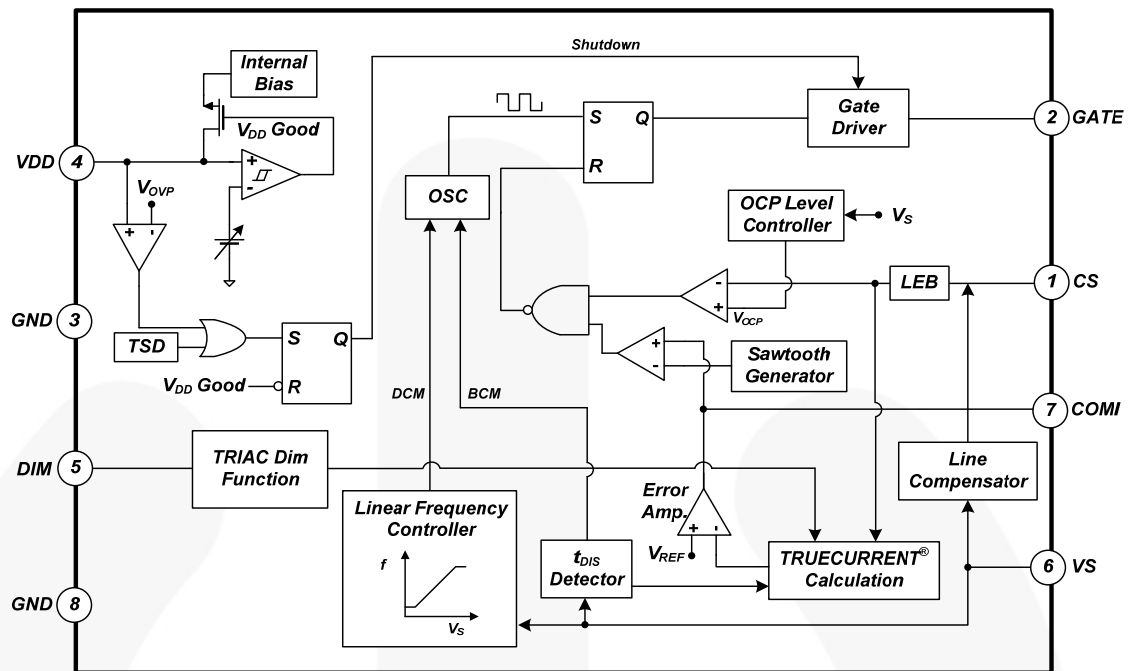

Figure 1. Internal Block Diagram

2. General Specifications

All data in Table 1 was measured at an ambient temperature of 25°C.

Table 1. Summary of Features and Performance for LED Lighting Bulb

Description	Symbol	Value	Comments
Input Voltage	$V_{IN,MIN}$	90V	Minimum Input Voltage
	$V_{IN,MAX}$	140V	Maximum Input Voltage
	$V_{IN,NOMINAL}$	110~120V	Nominal Input Voltage
Input Frequency	f_{IN}	60Hz	Line Frequency
Output Voltage Current	$V_{OUT,MIN}$	10V	Minimum Output Voltage
	$V_{OUT,MAX}$	28V	Maximum Output Voltage
	$V_{OUT,NOMINAL}$	22V	Nominal Output Voltage
	$I_{OUT,NOMINAL}$	380mA	Nominal Output Current
	$I_{OUT,RIPPLE}$	±65mA	Output Current Ripple
	CC Deviation		<±3.9%
<±2.1%			Output Voltage Change:10~28V
Efficiency	Note : No Dimmer Connected		
	Eff_{90VAC}	80.7%	Efficiency at 90V _{AC} Line Input Voltage
	Eff_{110VAC}	82.2%	Efficiency at 110V _{AC} Line Input Voltage
	Eff_{120VAC}	82.5%	Efficiency at 120V _{AC} Line Input Voltage
	Eff_{140VAC}	82.9%	Efficiency at 140V _{AC} Line Input Voltage
PF/THD	Note : No Dimmer Connected		
	PF/THD_{90VAC}	0.98/7.4%	PF/THD at 90V _{AC} Line Input Voltage
	PF/THD_{110VAC}	0.96/9.5%	PF/THD at 110V _{AC} Line Input Voltage
	PF/THD_{120VAC}	0.95/10.4%	PF/THD at 120V _{AC} Line Input Voltage
	PF/THD_{140VAC}	0.91/12.4%	PF/THD at 140 V _{AC} Line Input Voltage
Temperature	Note : Open-Frame Condition ($T_A=25^\circ C$)		
	T_{FL7730}	50°C	FL7730 Temperature
	T_{MOSFET}	53°C	Primary MOSFET Temperature
	T_{DIODE}	47°C	Secondary Diode Temperature
	$T_{TRANSFORMER}$	52°C	Transformer Temperature
	T_{DAMPER}	57°C	Active Damper Temperature
	$T_{STR.RESISTOR}$	56°C	Startup Resistor Temperature

3. Photographs



Figure 2. Top View of Evaluation Board

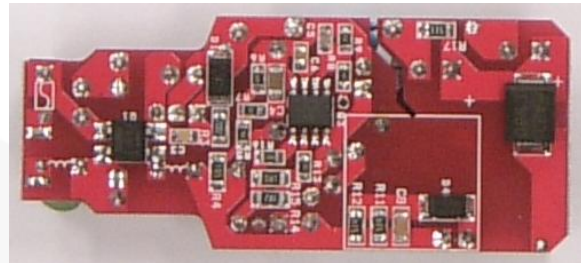

Figure 3. Bottom View of Evaluation Board

Dimensions: 62.5mm (L) × 26.8mm (W) × 12.0 (H)

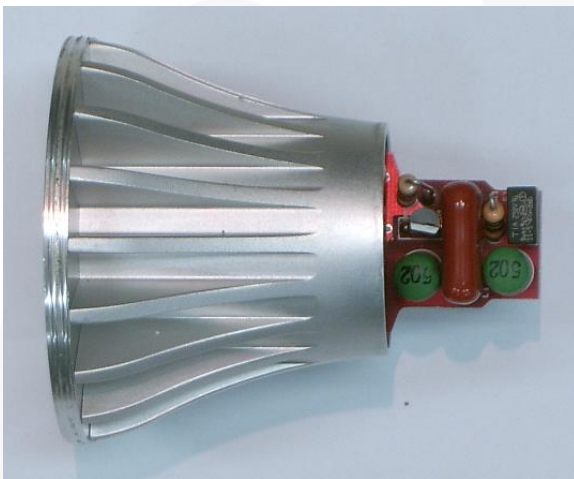

Figure 4. Side View in Bulb Case Type 1

Bulb Case Type 1 : 32mm (Case Diameter) × 40mm (Case Depth)

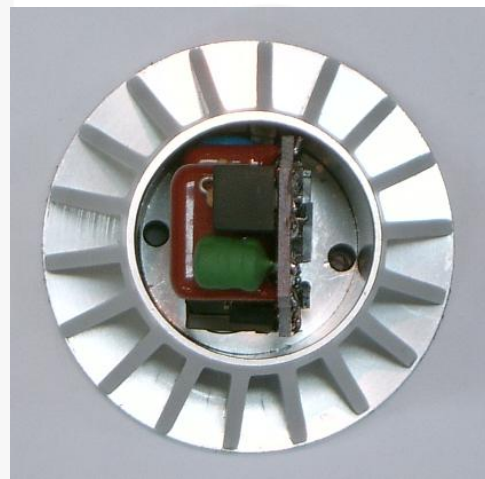

Figure 5. Bottom View in Bulb Case Type 1

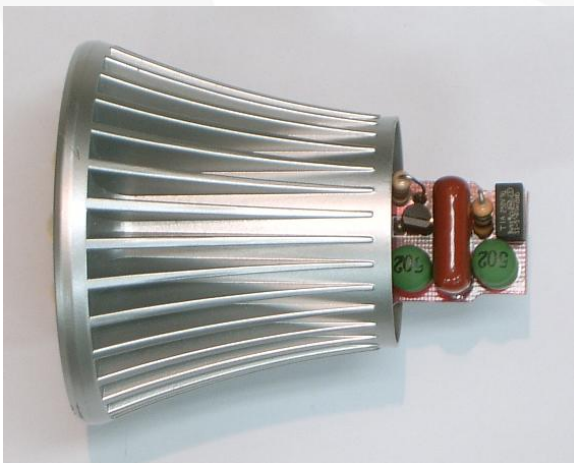

Figure 6. Side View in Bulb Case Type 2

Bulb Case Type 2 : 34mm (Case Diameter) × 44mm (Case Depth)

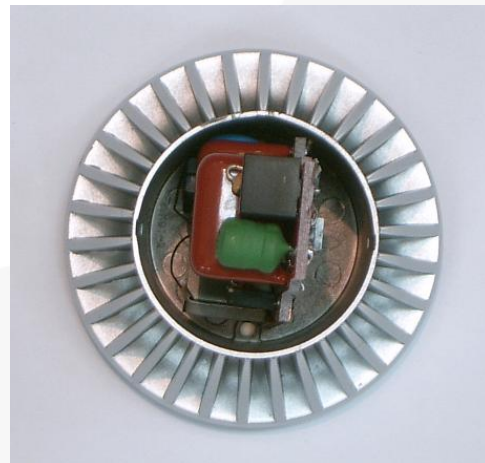

Figure 7. Bottom View in Bulb Case Type 2

4. Printed Circuit Board

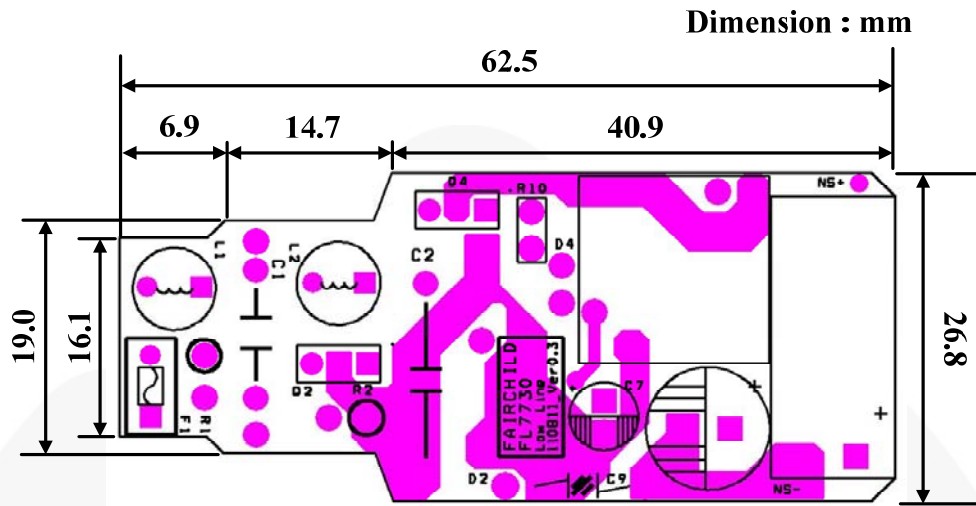

Figure 8. Printed PCB, Top Side

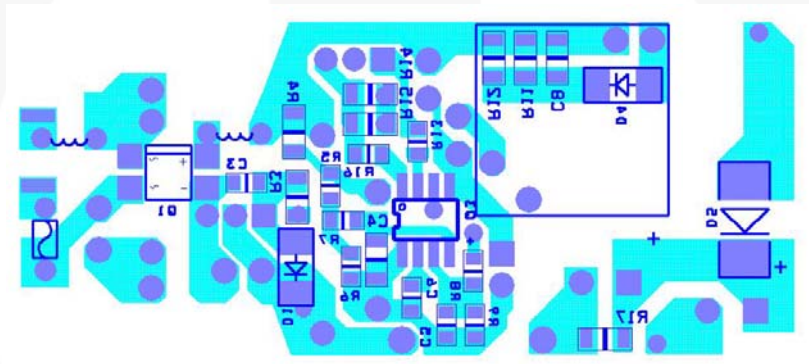

Figure 9. Printed PCB, Bottom Side

5. Schematic

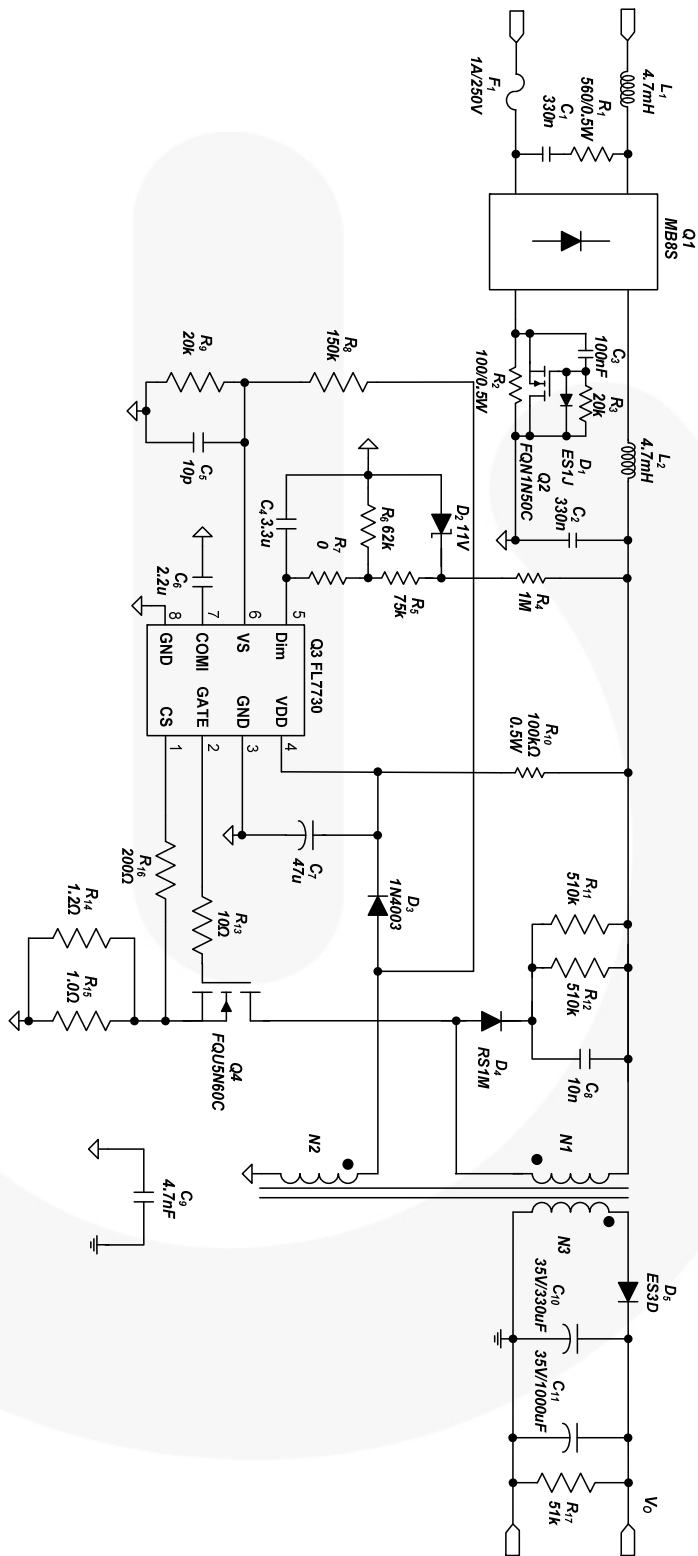

Figure 10. Schematic of Evaluation Board

2.1 Bill of Materials

Item No.	Part Reference	Part number	Qty	Description	Manufacturer
1	Q1	MB8S	1	Bridge Diode	Fairchild
2	Q2	FQN1N50C	1	1A/500V Active Damper MOSFET	Fairchild
3	Q3	FL7730	1	Main Controller	Fairchild
4	Q4	FQU5N60C	1	5A/600V Main Switch	Fairchild
5	F1	SS-5-1A	1	1A/250V Fuse	Bussmann
6	L1, L2	R06472KT00	2	4.7mH Filter Inductor	Bosung
7	D1	ES1J	1	1A/600V Diode	Fairchild
8	D2	1N5241	1	11V Zener Diode	Fairchild
9	D3	1N4003	1	1A/200V Diode	Fairchild
10	D4	RS1M	1	1A/1000V Diode	Fairchild
11	D5	ES3D	1	3A/200V Fast Rectifier	Fairchild
12	C1	MPE 400V334K 14S	1	334/400V Film Capacitor	Sungho
13	C2	MPE 400V334K 14S	1	334/400V Film Capacitor	Sungho
14	C3	C0805C104K3RACTU	1	104/25V SMD Capacitor 2012	Kemet
15	C4	C1206C335K3PACTU	1	335/25V SMD Capacitor 3216	Kemet
16	C5	C0805C100M3GACTU	1	10/25V SMD Capacitor 2012	Kemet
17	C6	C2012Y5V1E225Z	1	225/25V SMD Capacitor 2012	TDK
18	C7	KMG 47µF/35V	1	47µF/35V Electrolytic Capacitor	Samyoung
19	C8	C1206C103KDRACTU	1	103/1kV SMD Capacitor 3216	Kemet
20	C9	SCFz2E472M10BW	1	472/250V Y-Capacitor	Samwha
21	C10	KMG 330µF/35V	1	330µF/35V Electrolytic Capacitor	Samyoung
22	C11	RM 1000µF/35V	1	1000µF/35V Electrolytic Capacitor	Samwha
23	R1	SR03700005600KR500	1	560Ω/0.5W Metal Resistor	Vishay
24	R2	RNF12JTD100R	1	100Ω/0.5W Metal Resistor	Stackpole Elec.
25	R3	RC1206JR-0720KL	1	20kΩ SMD Resistor 3216	Yageo
26	R4	RC1206JR-071ML	1	1MΩ SMD Resistor 3216	Yageo
27	R5	RC0805JR-0775KL	1	75kΩ SMD Resistor 2012	Yageo
28	R6	RC0805JR-0762KL	1	62kΩ SMD Resistor 2012	Yageo
29	R7	0	1		
30	R8	RC0805JR-07150KL	1	150kΩ SMD Resistor 2012	Yageo
31	R9	RC0805JR-0720KL	1	20kΩ SMD Resistor 2012	Yageo
32	R10	RNF12GTD100K	1	100kΩ/0.5W Metal Resistor	Stackpole Elec.
33	R11, R12	RC1206JR-07510KL	2	510kΩ SMD Resistor 3216	Yageo
34	R13	RC0805JR-0710RL	1	10Ω SMD Resistor 2012	Yageo
35	R14	RC1206JR-071R2L	1	1.2Ω SMD Resistor 3216	Yageo
36	R15	RC1206FR-071RL	1	1.0Ω SMD Resistor 3216	Yageo
37	R16	RC0805JR-07200RL	1	200Ω SMD Resistor 2012	Yageo
38	R17	RC1206JR-0751KL	1	51kΩ SMD Resistor 3216	Yageo

2.2 Transformer and Winding Specifications

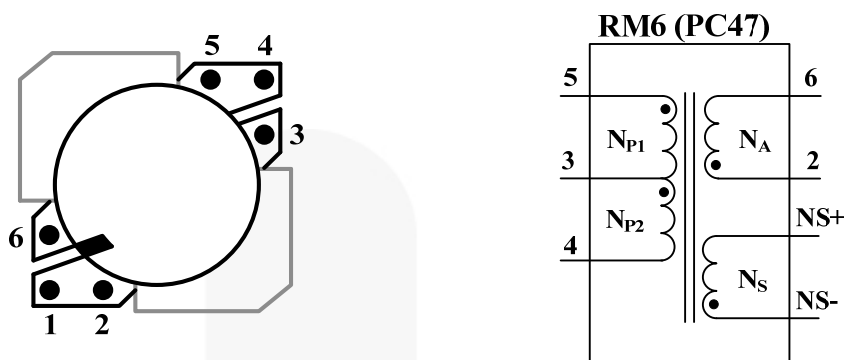

Figure 11. Transformer Specifications & Construction

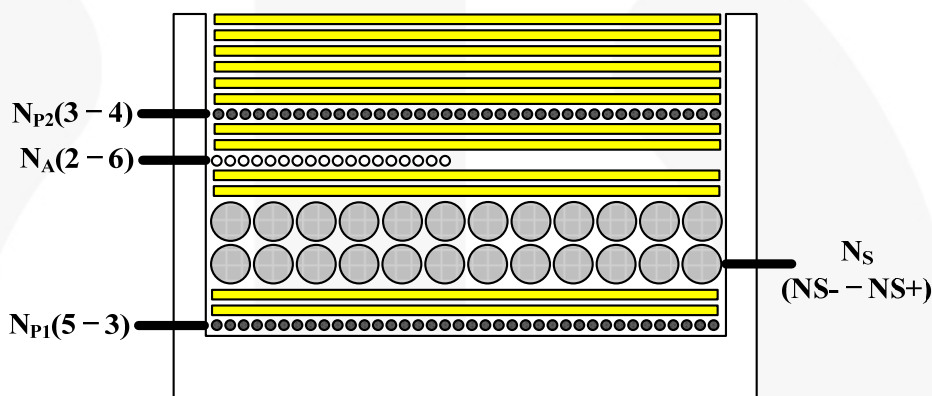

Figure 12. Transformer Winding Structure

Table 2. Winding Specifications

No.	Winding	Pin (S → F)	Wire	Turns	Winding Method
1	N_{P1}	5 → 3	0.13φ	38 Ts	Solenoid Winding
2	Insulation: Polyester Tape t = 0.025mm, 2 Layer				
3	N_S	NS- → NS+	0.3φ (TIW)	24 Ts	Solenoid Winding
4	Insulation: Polyester Tape t = 0.025mm, 2 Layer				
5	N_A	2 → 6	0.13φ	18 Ts	Solenoid Winding
6	Insulation: Polyester Tape t = 0.025mm, 2 Layer				
7	N_{P2}	3 → 4	0.13φ	38 Ts	Solenoid Winding
8	Insulation : Polyester Tape t = 0.025mm, 6 Layer				

Table 3. Electrical Characteristics

	Pin	Specification	Remark
Inductance	1- 2	1mH ±10%	50kHz, 1V
Leakage	1- 2	8μH	50kHz, 1V Short All Output Pins

6. Performance of Evaluation Board

6.1. Startup

Startup time is 0.8s. There is no overshoot at output current and voltage in startup sequence (refer I_{OUT} and V_{DD} waveform. V_{DD} indicates a reflected output voltage).

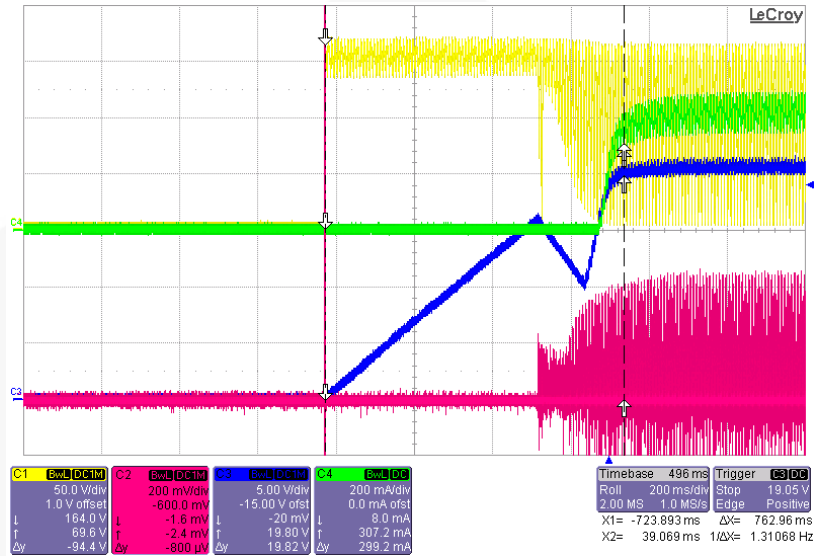

Figure 13. Startup – V_{IN} [110V_{AC}], C1 [V_{IN}], C2 [V_{CS}], C3 [V_{DD}], C4, [I_{OUT}], (No Dimmer Connected)

6.2. Operation Waveforms

In steady state, line compensation regulates output current regardless of input voltage variations. Output current ripple is ± 65 mA with a rated output current of 380mA.

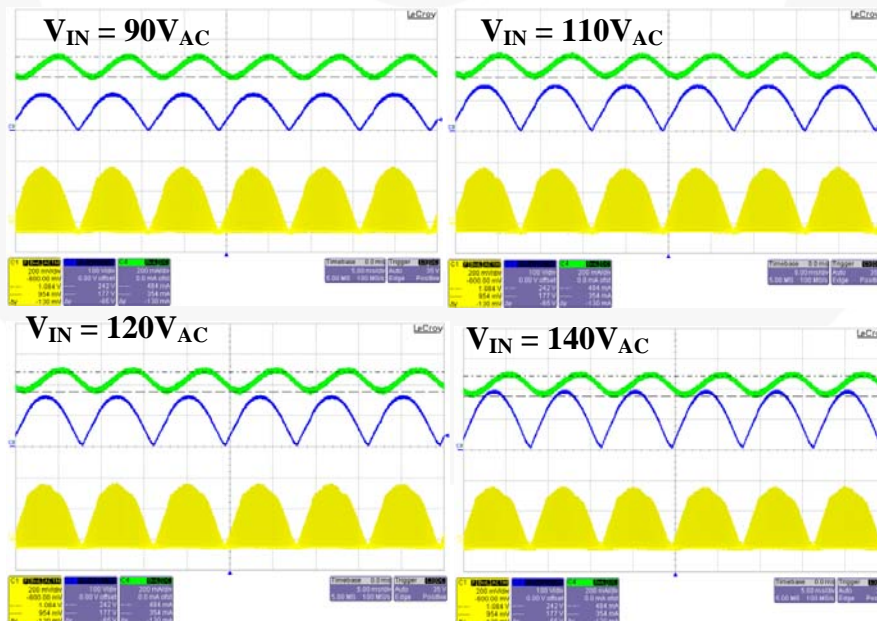

Figure 14. Operation Waveforms – V_O [22V], I_O [380mA], C1 [V_{CS}], C3, [V_{IN}], C4 [I_{OUT}]

6.3. Constant Current Regulation

Constant current deviation in the output voltage range from 10V to 28V is less than 2.1% at each line input voltage. Line regulation at the rated output voltage (22V) is less than 3.9%.

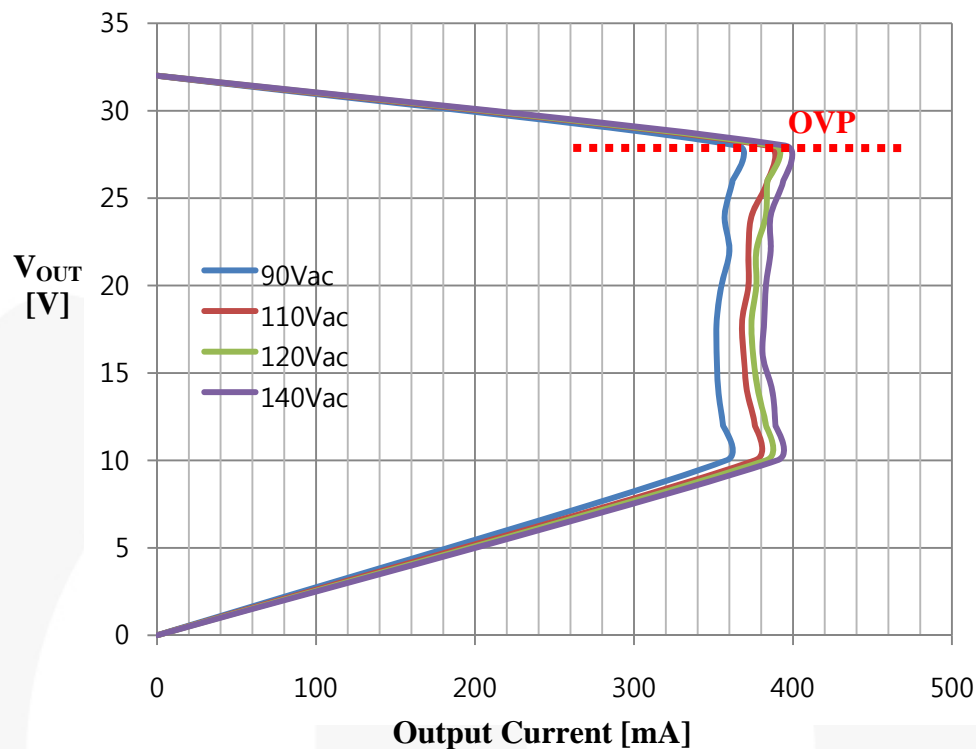

Figure 15. Constant Current Regulation – Measured by E-Load [CR Mode]

Table 4. Constant Current Regulation by Output Voltage Change (10~28V)

Input Voltage	Min. Current	Max. Current	Tolerance
90V _{AC} / 60Hz	352mA	365mA	±1.8%
110V _{AC} / 60Hz	368mA	384mA	±2.1%
120V _{AC} / 60Hz	374mA	388mA	±1.8%
140V _{AC} / 60Hz	381mA	395mA	±1.8%

Table 5. Constant Current Regulation by Line Voltage Change (90~140V_{AC})

Output Voltage	90V _{AC}	110V _{AC}	120V _{AC}	140V _{AC}	Tolerance
20V	355mA	372mA	377mA	383mA	±3.8%
22V	360mA	372mA	377mA	386mA	±3.5%
24V	357mA	374mA	383mA	386mA	±3.9%

6.4. Open/Short-LED Protections

In short-LED condition, the OCP level is reduced from 0.7V to 0.2V because the FL7730 lowers the OCP level when V_S voltage is less than 0.4V during output diode conduction time. The output current in the short-LED condition is less than 1.5A, which doesn't damage any external components.

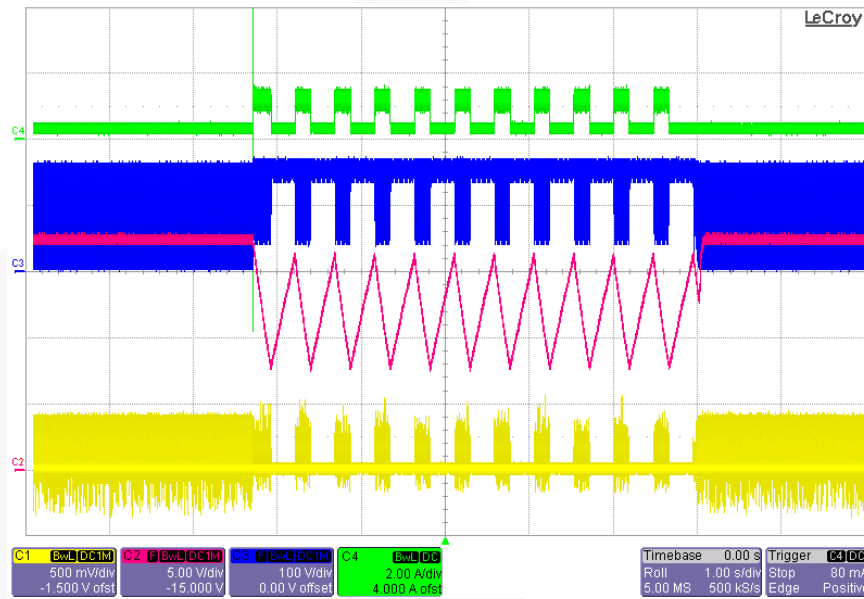

Figure 16. Short-LED Condition – V_{IN} [110V_{AC}], C1 [V_{CS}], C2 [V_{DD}], C3 [V_{IN}], C4 [I_{OUT}]

In open-LED condition, output voltage is limited around 32V by OVP in V_{DD} . The output over-voltage protection level can be controlled by turn ratio of auxiliary and secondary windings.

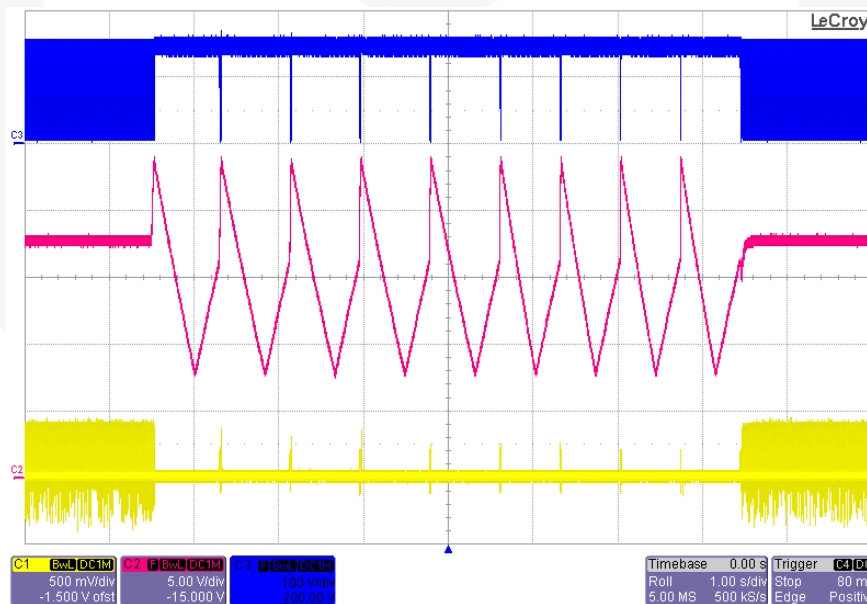

Figure 17. Open-LED Condition – V_{IN} [110V_{AC}], C1 [V_{CS}], C2 [V_{DD}], C3 [V_{IN}]

6.5. Dimming Operation

Dimming operation waveforms are shown in Figure 18 - Figure 20. Active damper, RC bleeder, and dimming control in FL7730 implement flicker-free dimming operation. Spike current at dimmer firing is less than 1.2A.

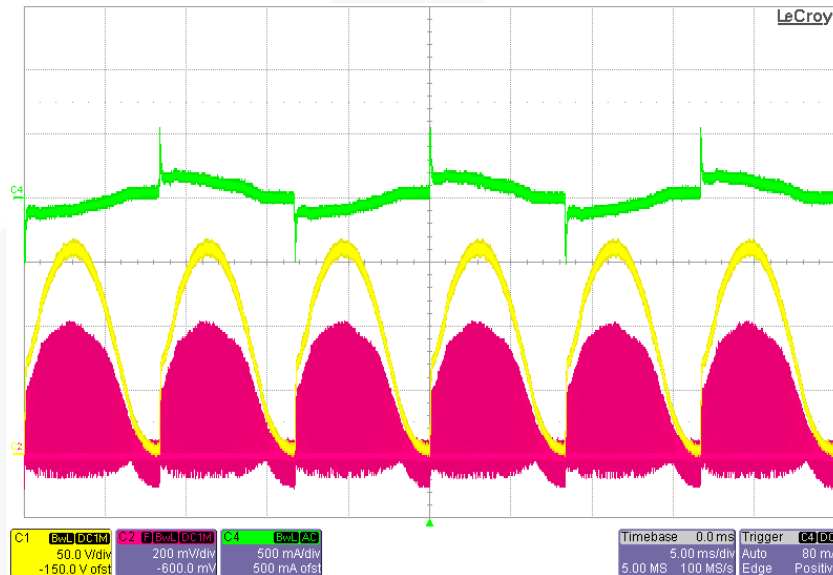

Figure 18. Dimming Operation Waveforms: Max. Dimming Angle, V_{IN} [120V_{AC}], C1 [V_{IN}], C2 [V_{CS}], C4 [I_{IN}]

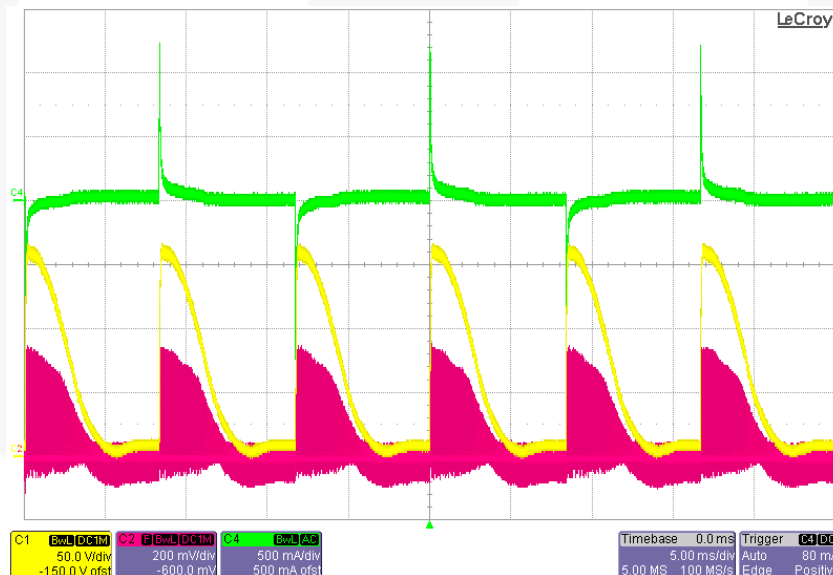

Figure 19. Dimming Operation Waveforms : 90° Dimming Angle, V_{IN} [120V_{AC}], C1 [V_{IN}], C2 [V_{CS}], C4 [I_{IN}]

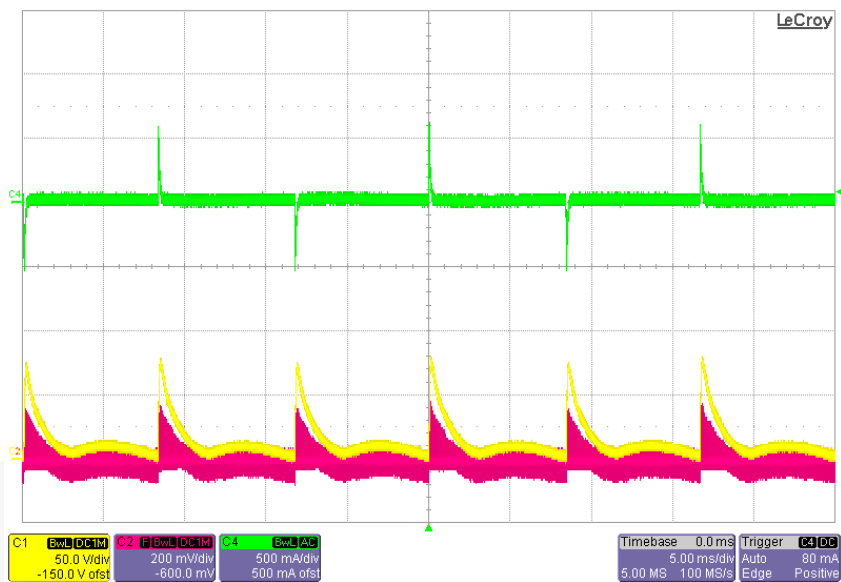

Figure 20. Dimming Operation Waveforms – Min. Dimming Angle, V_{IN} [120V_{AC}], C1 [V_{IN}], C2 [V_{CS}], C4 [I_{IN}]

Output current is controlled by dimming function when rotating dimmer switch as in the dimming curve in Figure 21. The dimming control block in FL7730 smoothly changes regulated output current by detecting dimming angle.

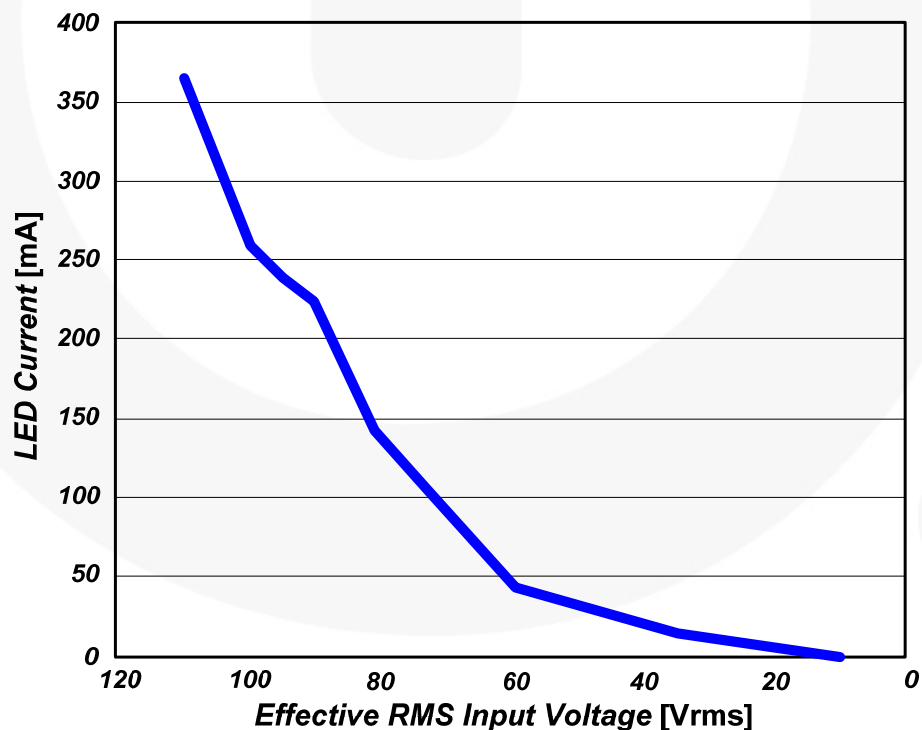

Figure 21. Dimming Curve (Effective RMS Input Voltage vs. Output Current) – Line Voltage [120V_{AC}]

Table 6. TRIAC Dimmer Compatibility

Manufacturer	Dimmer	Condition	Maximum Current	Minimum Current	Flicker
LUTRON	S-600P-WH	120V / 60Hz	330mA	40mA (12.0%)	No
LUTRON	CN-600P-WH	120V / 60Hz	328mA	11mA (3.4%)	No
LUTRON	GL-600H	120V / 60Hz	365mA	8mA (2.2%)	No
LUTRON	TG-603PGH-WH	120V / 60Hz	252mA	12mA (4.8%)	No
LUTRON	TG-600PH-WH	120V / 60Hz	333mA	14mA (4.2%)	No
LUTRON	LG-600P	120V / 60Hz	327mA	3mA (0.9%)	No
LUTRON	CTCL-153PD	120V / 60Hz	320mA	58mA (18.0%)	No
LEVITON	IP106	120V / 60Hz	380mA	36mA (9.5%)	No
LEVITON	1C4005	120V / 60Hz	344mA	0mA (0%)	No
LEVITON	6631-LW	120V / 60Hz	340mA	0mA (0%)	No
Legrand	F 165H	120V / 60Hz	344mA	3mA (0.9%)	No

6.6. System Efficiency

Power efficiency is 80.7 ~ 82.9% in 90 ~ 140V_{AC} input voltage range.

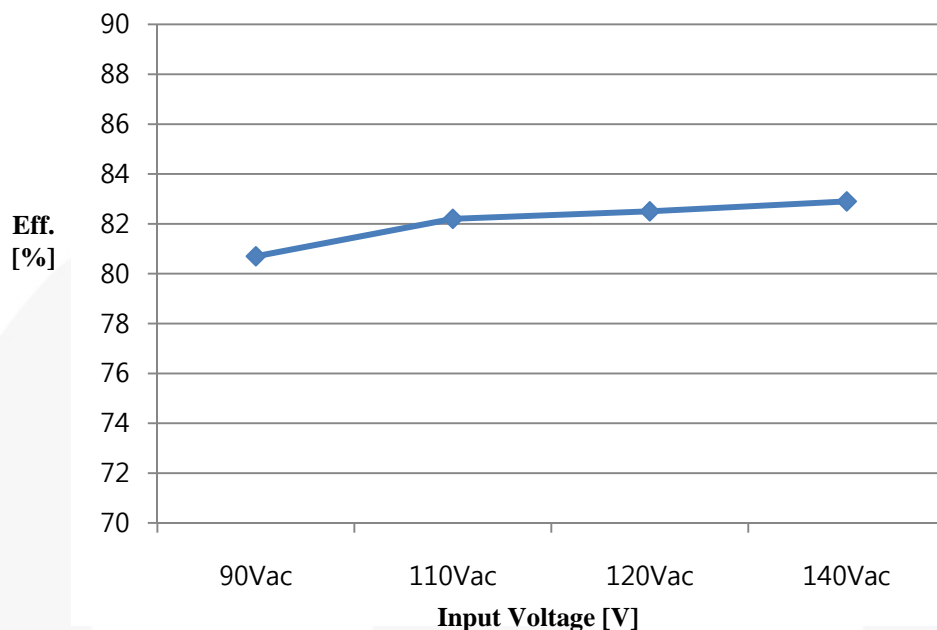

Figure 22. Power Efficiency (Input Voltage vs. Efficiency)

Table 7. System Efficiency

Input Voltage	Input Power	Output Current	Output Voltage	Output Power	Efficiency
90V _{AC}	9.68W	360mA	21.70V	7.81W	80.7%
110V _{AC}	9.96W	376mA	21.77V	8.19W	82.2%
120V _{AC}	10.02W	380mA	21.77V	8.27W	82.5%
140V _{AC}	10.15W	386mA	21.79V	8.41W	82.9%

6.7. Power Factor and THD

FL7730 shows excellent power factor and THD performance. Power factor is very high with enough margins from 0.9. THD is much less than 30% specification.

Table 8. Power Factor and THD

Input Voltage	Output Current	Output Voltage	PF	THD
90V _{AC}	360mA	21.70V	0.98	7.4%
110V _{AC}	376mA	21.77V	0.96	9.5%
120V _{AC}	380mA	21.77V	0.95	10.4%
140V _{AC}	386mA	21.79V	0.91	12.4%

6.8. Operating Temperature

Temperature of the all components on this board is less than 60°C.

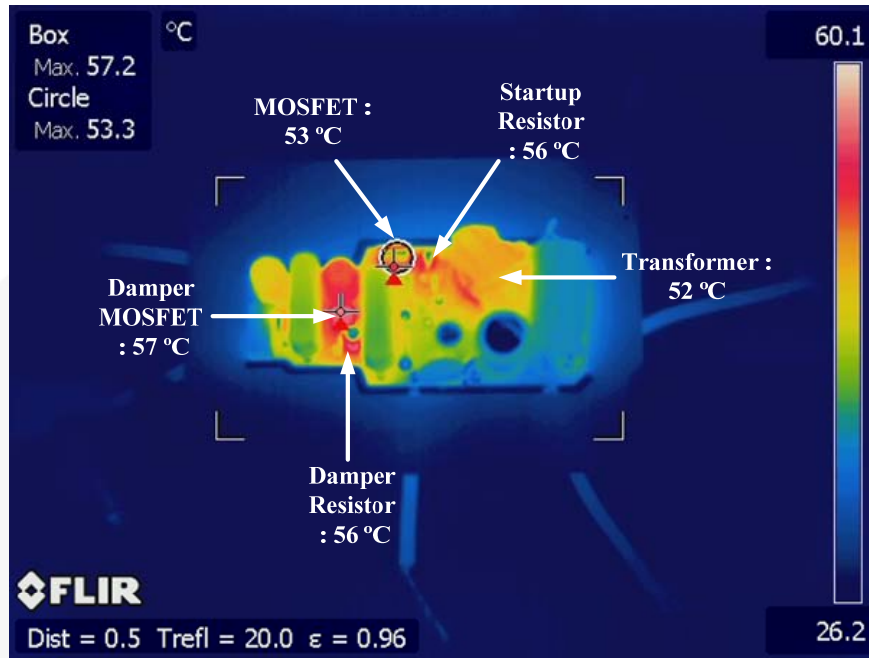

Figure 23. Board Temperature - Top View, V_{IN} [120V_{AC}], I_o [380mA]

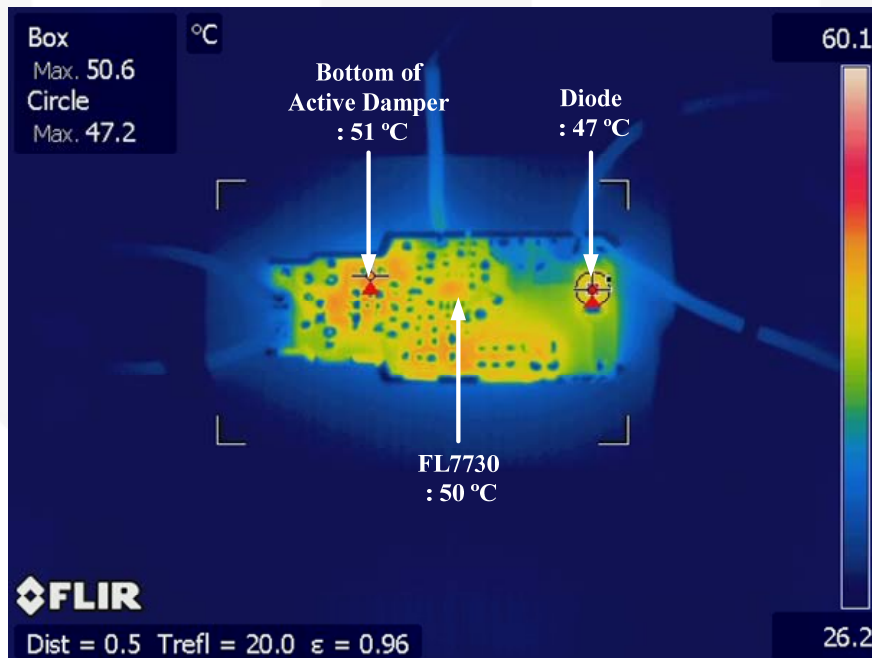

Figure 24. Board Temperature - Bottom View, V_{IN} [120V_{AC}], I_o [380mA]

6.9. EMI

The all measurement was conducted in observance of CISPR22 criteria.

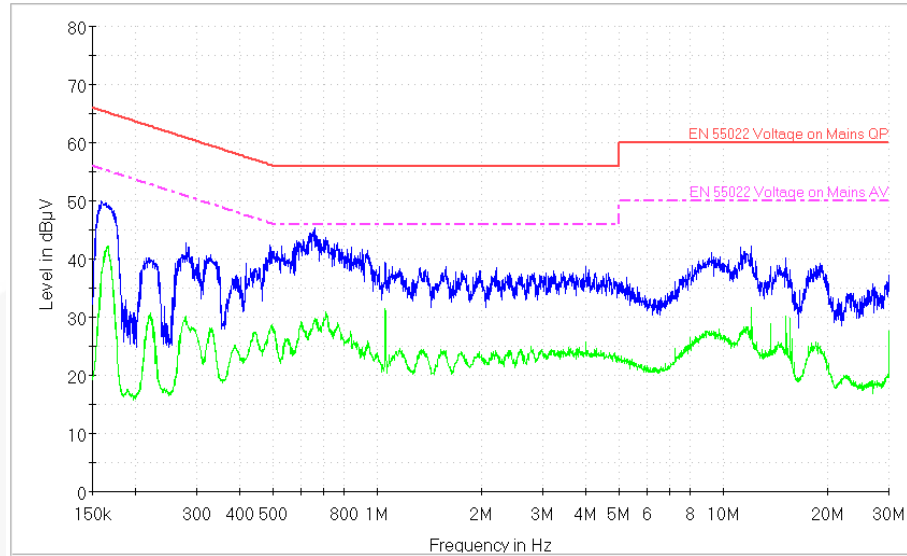

Figure 25. EMI Results – V_{IN} [110V], V_{OUT} [22V], I_{OUT} [380mA]

7. Revision History

Rev.	Date	Description
0.0.1	FEB 23, 2012	Change User Guide number from FEB-L020-1 to FEBFL7730_L20L008A
0.0.2	FEB 24, 2012	Initial edit/format pass
0.0.3	FEB 28, 2012	Initial edit (Part list, figure number)
0.0.4	MAR 8, 2012	BOM revision and minor error correction

WARNING AND DISCLAIMER

Replace components on the Evaluation Board only with those parts shown on the parts list (or Bill of Materials) in the Users' Guide. Contact an authorized Fairchild representative with any questions.

This board is intended to be used by certified professionals, in a lab environment, following proper safety procedures. Use at your own risk. The Evaluation board (or kit) is for demonstration purposes only and neither the Board nor this User's Guide constitute a sales contract or create any kind of warranty, whether express or implied, as to the applications or products involved. Fairchild warrants that its products meet Fairchild's published specifications, but does not guarantee that its products work in any specific application. Fairchild reserves the right to make changes without notice to any products described herein to improve reliability, function, or design. Either the applicable sales contract signed by Fairchild and Buyer or, if no contract exists, Fairchild's standard Terms and Conditions on the back of Fairchild invoices, govern the terms of sale of the products described herein.

DISCLAIMER

FAIRCHILD SEMICONDUCTOR RESERVES THE RIGHT TO MAKE CHANGES WITHOUT FURTHER NOTICE TO ANY PRODUCTS HEREIN TO IMPROVE RELIABILITY, FUNCTION, OR DESIGN. FAIRCHILD DOES NOT ASSUME ANY LIABILITY ARISING OUT OF THE APPLICATION OR USE OF ANY PRODUCT OR CIRCUIT DESCRIBED HEREIN; NEITHER DOES IT CONVEY ANY LICENSE UNDER ITS PATENT RIGHTS, NOR THE RIGHTS OF OTHERS.

LIFE SUPPORT POLICY

FAIRCHILD'S PRODUCTS ARE NOT AUTHORIZED FOR USE AS CRITICAL COMPONENTS IN LIFE SUPPORT DEVICES OR SYSTEMS WITHOUT THE EXPRESS WRITTEN APPROVAL OF THE PRESIDENT OF FAIRCHILD SEMICONDUCTOR CORPORATION.

As used herein:

- Life support devices or systems are devices or systems which, (a) are intended for surgical implant into the body, or (b) support or sustain life, or (c) whose failure to perform when properly used in accordance with instructions for use provided in the labeling, can be reasonably expected to result in significant injury to the user.
- A critical component is any component of a life support device or system whose failure to perform can be reasonably expected to cause the failure of the life support device or system, or to affect its safety or effectiveness.

ANTI-COUNTERFEITING POLICY

Fairchild Semiconductor Corporation's Anti-Counterfeiting Policy. Fairchild's Anti-Counterfeiting Policy is also stated on our external website, www.fairchildsemi.com, under Sales Support.

Counterfeiting of semiconductor parts is a growing problem in the industry. All manufacturers of semiconductor products are experiencing counterfeiting of their parts. Customers who inadvertently purchase counterfeit parts experience many problems such as loss of brand reputation, substandard performance, failed applications, and increased cost of production and manufacturing delays. Fairchild is taking strong measures to protect ourselves and our customers from the proliferation of counterfeit parts. Fairchild strongly encourages customers to purchase Fairchild parts either directly from Fairchild or from Authorized Fairchild Distributors who are listed by country on our web page cited above. Products customers buy either from Fairchild directly or from Authorized Fairchild Distributors are genuine parts, have full traceability, meet Fairchild's quality standards for handling and storage and provide access to Fairchild's full range of up-to-date technical and product information. Fairchild and our Authorized Distributors will stand behind all warranties and will appropriately address any warranty issues that may arise. Fairchild will not provide any warranty coverage or other assistance for parts bought from Unauthorized Sources. Fairchild is committed to combat this global problem and encourage our customers to do their part in stopping this practice by buying direct or from authorized distributors.

EXPORT COMPLIANCE STATEMENT

These commodities, technology, or software were exported from the United States in accordance with the Export Administration Regulations for the ultimate destination listed on the commercial invoice. Diversion contrary to U.S. law is prohibited.

U.S. origin products and products made with U.S. origin technology are subject to U.S. Re-export laws. In the event of re-export, the user will be responsible to ensure the appropriate U.S. export regulations are followed.