

FLR- / FLK - WIRE
 FLR- / FLK - Leitung

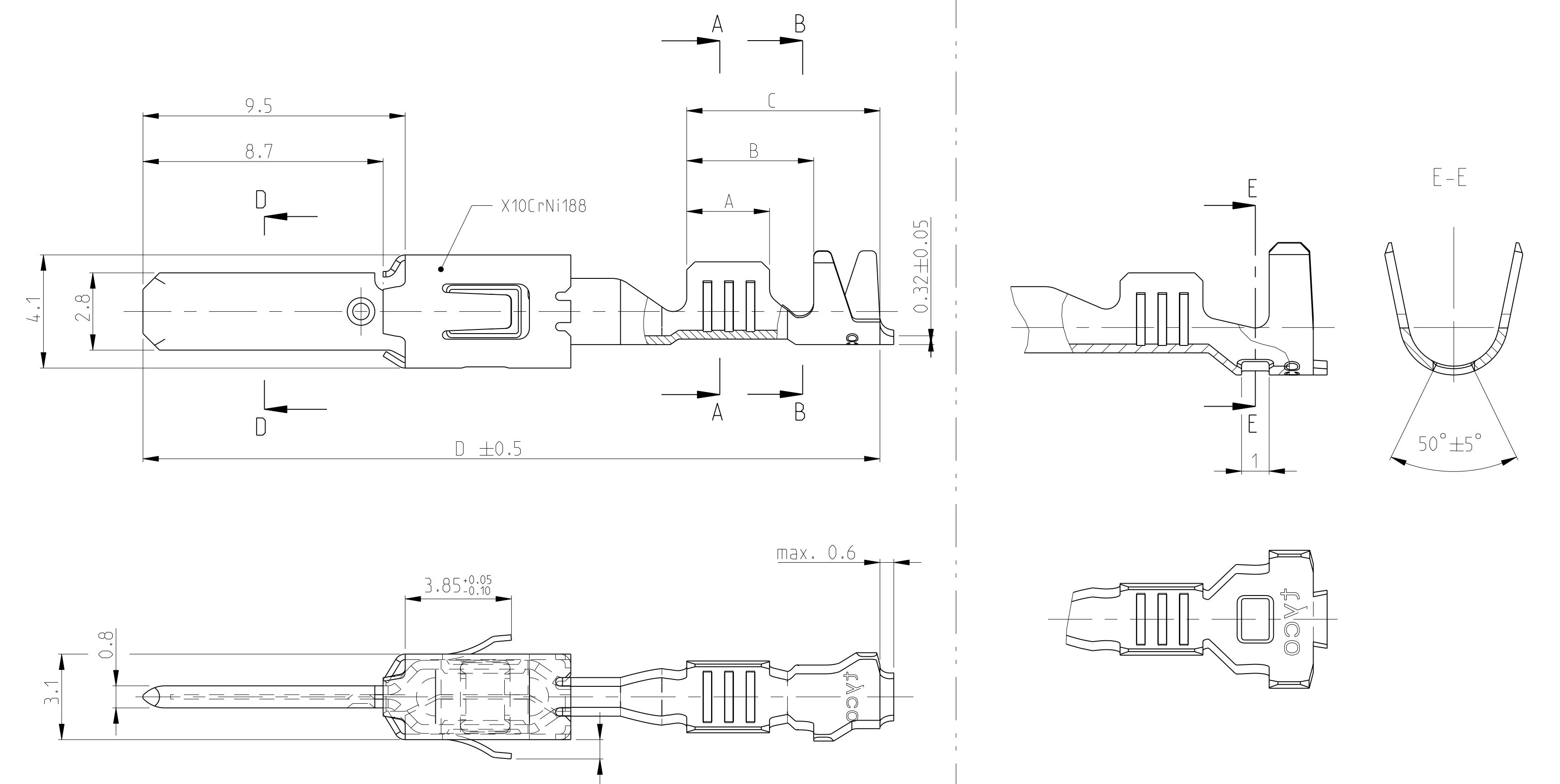

TE ORDER-NO. STRIPFORM Bandware	REV	TE ORDER-NO. LOOSE PIECE Einzelausführung	MATERIAL Werkstoff	SURFACE Oberfläche	DGB mm ²	INSULATION Isolationsø	SEE / siehe SECTION A-A Schnitt A-A	SEE / siehe SECTION B-B Schnitt B-B	SEE / siehe WIRE CRIMP Drahtcrimp	SEE / siehe SECTION A-A Schnitt A-A	SEE / siehe SECTION B-B Schnitt B-B	APPLICATION TOOL Anschlagwerkzeug	HAND TOOL Handzange	TE ORDER-NO. SINGLE WIRE SEAL Einzeldichtungssystem					
1-1719504-2	A	-	CuSn4	△	12 AWG	max. 3.0	E = 4.0 G = 4.2 D _{Dr} = 2.0	H = 5.3 K = 5.0 D = 3.6	AWG 12 = 2.0	-	-	1852291-3	-	3.5	6.0	7.6	26.8	△	
3-968947-1	A	3-968966-1	CuSn0.20	△	FLR	max. 3.7	E = 4.5 G = 4.7 D _{Dr} = 2.3	H = 6.2 K = 6.0 D = 4.3	4.0 mm ² = 2.25	DIMENSION SEE STRIP FORM		MQC APPLICATOR 2-541537-2	MTRIZZE : 539635-1 539727-2	4.3	6.0	8.5	28.5	828985	△
2-968947-2	A	2-968966-2	CuFe	△						E = 3.6 G = 3.8 D _{Dr} = 1.7	H = 5.3 K = 5.0 D = 3.6								
1-968947-2	A	1-968966-2	CuSn4	△	FLR	max. 2.1	E = 2.6 G = 2.9 D _{Dr} = 1.2	H = 5.0 K = 4.8 D = 3.3	1.0 mm ² = 1.36 0.75 mm ² = 1.27 0.5 mm ² = 1.18	E = 2.2 G = 2.9 D _{Dr} = 1.1	H = 4.6 K = 4.3 R = 2.3	MQC APPLICATOR 2-878559-2	734438-1	3.0	5.4	7.0	26.8	828904	△
1-968947-1	A	1-968966-1	CuFe	△															
2-962843-3	C	2-963747-3	CuFe	△	FLK	2.4 - 3.7	E = 3.6 G = 3.8 D _{Dr} = 1.7	H = 5.5 K = 5.7 D = 3.2	2.5 mm ² = 1.88 1.5 mm ² = 1.58	E = 2.8 G = 3.9 D _{Dr} = 1.7	H = 4.2 K = 5.1 R = 2.4	MQC APPLICATOR 2-878552-2	734417-3	3.6	5.2	8.9	28.6		
2-962843-2	C	2-963747-2	CuSn4	△															
1-962843-3	C	1-963747-3	CuSn4	△	FLR	2.1 - 2.9	E = 3.6 G = 3.8 D _{Dr} = 1.7	H = 4.3 K = 4.5 D = 2.6	2.5 mm ² = 1.88 1.5 mm ² = 1.58	E = 2.8 G = 3.9 D _{Dr} = 1.7	H = 3.6 K = 4.1 R = 2.1	MQC APPLICATOR 2-878551-2	734417-2	3.6	5.2	8.2	27.9		
1-962843-1	C	1-963747-1	CuFe	△															
3-968946-1	A	3-968965-1	CuSn0.20	△	FLR	1.3 - 1.6	E = 2.1 G = 2.1 D _{Dr} = 0.8	H = 2.9 K = 2.9 D = 1.4	0.5 mm ² = 1.12 0.35 mm ² = 1.05 0.2 mm ² = 0.98	E = 1.7 G = 2.1 D _{Dr} = 0.8	H = 2.5 K = 2.5 R = 1.4	MQC APPLICATOR 2-878549-2	734538-1	2.5	3.7	5.8	25.5		
2-962842-3	E	2-963746-3	CuFe	△															

DESIGN FOR PN 968946
 Ausführung PN 968946

- NOTES
 Bemerkungen
- △ CONTACT AREA PRE SILVER MIN. 3 µm
 CANTILEVER SPRING PLAIN
 Kontaktzone vorversilbert min. 3 µm
 Ueberfeder blank
 - △ CONTACT BODY NI-PLATING MIN. 0.5 µm; CONTACT AREA PRE-GOLD MIN. 0.6 µm
 OVER NICKEL; CRIMP AREA PRE-TIN
 CANTILEVER SPRING PLAIN
 Kontaktkörper vernickelt min. 0.5 µm; Kontaktzone vorvergoldet min. 0.6 µm ueber Nickel
 Crimpzone vorverzinkt; Ueberfeder blank
 - △ IN THIS AREA CRACK SHAPING AT THE SURFACE PERMISSIBLE
 In diesem Bereich Rissbildung in der Oberfläche zulaessig
 - △ PRE-TIN MIN. 1 µm; CANTILEVER SPRING PLAIN
 vorverzinkt min. 1 µm; Ueberfeder blank
 - △ AWG 12 TXL 828905-1 DR / oder 282536-1
 AWG 12 GXL 638865-1
 - △ ATTENTION! CONSTRUCTION OF THE CONTACT CAVITY IN THE AREA OF THE SINGLE WIRE SEAL IS Ø6.4^{+0.1}_{-0.05}
 Achtung! Die Kammer ist im Bereich der Einzeldichtung auf Ø6.4^{+0.1}_{-0.05} auszuliegen
 - △ PUNCHED WITH VOLATILIZING STAMPING-OIL
 Gestanzt mit verfluechtigendem Stanzoel

