

RFI Shield Clips

Shield Clips for EMI/RFI Shields

- ❖ SMT devices offering a fast solution for assembling RFI shields to PCBs.
- ❖ Eliminates the need for through holes and post reflow operations.
- ❖ Saves PCB real estate.
- ❖ Facilitates easy removal of the can for maintenance and repair.
- ❖ Substantial improvement in time and simplicity of assembly tuning and re-work.

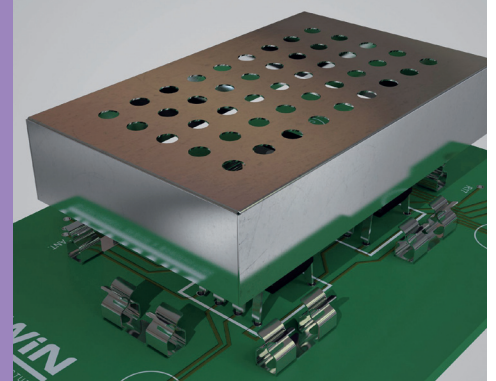

SPECIFICATION

❖ Materials

Material: Beryllium Copper or Cupro-Nickel (Beryllium-free)
 Finish: Tin

❖ Packaging

Packaging format: Tape & Reel or Loose
 Reel quantity: Midi: 1,900 on a Ø330mm reel
 Mini: 5,000 on a Ø330mm reel
 Maxi: 1,900 on a Ø330mm reel

❖ Electrical

Contact resistance: Midi, Maxi: 20 mΩ max
 Mini: 40 mΩ max

❖ Mechanical

Shield thickness: Midi: 0.30mm, Maxi: 0.7-1.0mm
 Mini: 0.13 – 0.23mm
 Insertion force (max): Mini: 5.0N (0.17mm shield)
 Midi: 4.0N
 Maxi: 7.0N (1mm shield)
 Withdrawal force (min): Mini: 0.35N
 Midi: 0.5N
 Maxi: 0.8N (0.7mm shield)

MINI

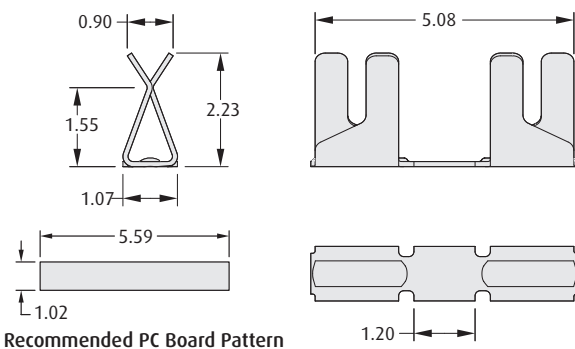

MIDI & MAXI

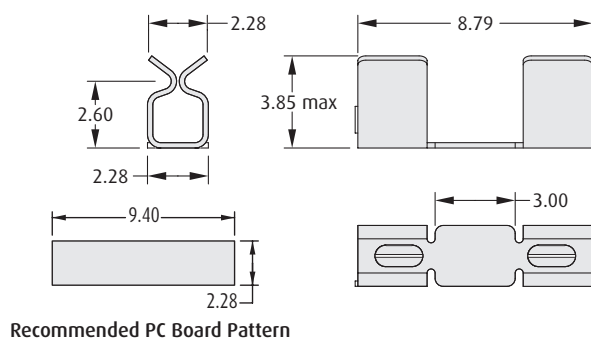

HOW TO ORDER

S XXX 1 - 46 R

SERIES CODE

TYPE

141	Maxi clip in Beryllium Copper
171	Midi clip in Beryllium Copper
172	Mini clip in Beryllium Copper
271	Midi clip in Cupro-Nickel

PACKAGING

R	Tape & Reeled
Blank	Loose

FINISH

46 Tin



All dimensions in mm.