

Materials

1. Insulator, PBT + 15% glass fiber, white
2. Shell, C2700 brass, 2 μm nickel plated
3. Spring contact, C5191 phosphor bronze, 2 μm nickel plated

Electrical requirements

Dielectric strength: 1 min @ 500 Vac
 Insulation resistance: 100 MΩ @ 500 Vdc
 Contact resistance: 30 mΩ or less
 Rated voltage: 20 Vdc
 Rated current: 7 A

Mechanical requirements

Insertion force: 0.3-3 kgf
 Withdrawal force: 0.3-3 kgf
 Durability: 5000 mating cycles while maintaining: 0.3-2 kgf insertion force, 0.2-1.5 kgf withdrawal force and a less than 100 mΩ contact resistance.

Environmental requirements

Damp test: 40 °C, RH 90-100% for 96 hrs. Cool to ambient and recover for 2 hours. Maintain dielectric strength of 500 Vac for 1 min, insulation resistance of 50 MΩ @ 500 Vdc minimum and a contact resistance of 100 mΩ or less.

Dry test: 70 °C, RH 70-85% for 96 hrs. Cool to ambient and recover for 2 hours. Maintain insulation resistance of 50 MΩ @ 500 Vdc minimum and a contact resistance of 100 mΩ or less.

Salt spray test: 35 °C, RH 90-95%, 5% NaCl mist for 24 hrs. Wash parts after test. Maintain mechanical requirements and a contact resistance of less than 80 mΩ.

Operating range

-25 to 70 °C, relative humidity of 85% or less

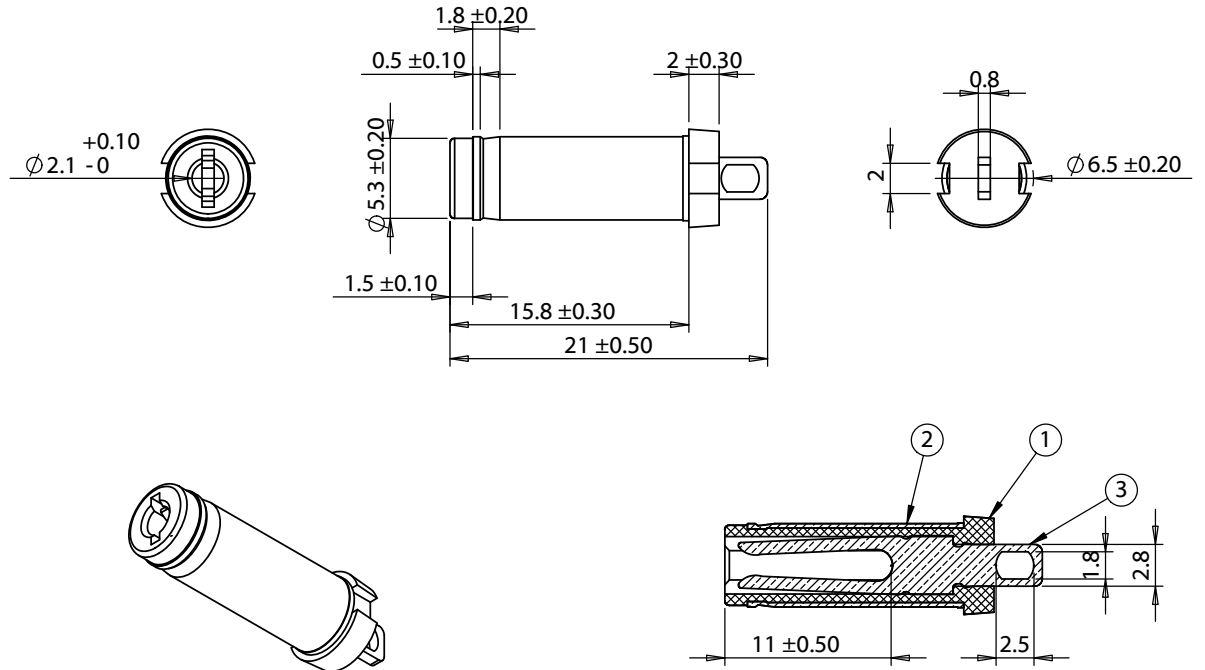

Revision	Date	Description
A	11/7/2012	Initial release

Notes	
RoHS compliant	
Function test: no open, no short circuit, no INT	
DIMENSIONS ARE IN MILLIMETERS	DESCRIPTION:
TOLERANCES: X: ± 0.5 mm X.X: ± 0.3 mm X.XX: ± 0.05 mm	Connector, dc plug, 5.5x2.1xL21mm, brass, nickel-plated, molding type, white insulators

TENSILITY

20802 Sockeye Place #130
 Bend, OR 97701 USA
 tel 541.323.3228 fax 541.323.4202
 800 877.670.7118 www.tensility.com

SIZE	Part number
A	50-00313
SCALE: 2:1	WEIGHT:
SHEET 1 OF 1	